

# **Contract Report**

## **Procedures for Calculating Natural Ventilation Airflow Rates in Buildings**

Work Performed for  
ASHRAE Research Project 448-RP

Final report  
FSEC-CR-163-86  
March, 1987

Muthusamy V. Swami  
Subrato Chandra

**Florida Solar Energy Center**  
300 State Road 401  
Cape Canaveral, Florida 32920



## SUMMARY

This is the final report of ASHRAE research project 448-RP "Building Pressure Distribution for Natural Ventilation" initiated in October 1985. The objective of the research was to review the worldwide data on building pressure coefficient and to assimilate the data for use in hourly calculation of natural ventilation airflow rates in buildings. This report is organized in two parts. Part 1 is written for the user who wants to use the information. Part 2 provides the background and research data analysis which was conducted to come up with the Part 1 information.

The worldwide database on building pressure ( $C_p$ ) distribution was reviewed and usable detailed data on low rise and high rise buildings were extracted. Data was assimilated from eight different investigators for low rise buildings and one source for high rise buildings. For low rise buildings, it was found that surface average pressure coefficients were adequate and several thousand local data were assimilated as 544 surface average  $C_p$ . A non linear regression with wind incidence angle and building side ratio as variables was found to predict this data with a correlation coefficient of 0.80.

For high rise buildings, local pressure coefficients (rather than surface average) were used. The 5000+ data points were fitted with another non linear regression involving the earlier variables plus the location coordinates. Over 80% of the effort in this project went into the development of these regression equations and is detailed in part 2 of this report. These building pressure coefficient correlations developed in this work can be useful for infiltration and indoor quality studies as well as for natural ventilation airflow calculations.

Part 1 of this report presents a structured procedure for calculating wind driven natural ventilation air flow rates. This procedure is based on the Vickery algorithm for calculating airflows with enhancements to the procedure for handling the following special cases:

- o Projecting windows and insect screens
- o Minimum ventilation rates in zero wind conditions
- o Effect of surrounding buildings
- o Ventilation in windows only on one wall.

The recommended procedure was verified by comparing it to measured natural ventilation air flow rates in a full scale 3 bedroom 2 bath house (see part 2, Section 2.7). It was found that the procedure predicted measured airflow rates to within 10%.

We believe that the procedure is a significant enhancement to the state of art. However the procedure has many limitations which are spelled out in detail in part 1. The most severe limitation is that the entire available Cp database is on rectangular buildings. Therefore, common houses with garages and porches which have L, U or more complex shapes cannot be readily analysed. It is recommended that ASHRAE consider research funding for obtaining Cp data on non rectangular buildings. Not only will this be important for natural ventilation calculations but will be vital for accurate infiltration calculations and its attendant impact on energy conservation and indoor air quality.

Readers are encouraged to review and critique the document. Please send all comments to:

Subrato Chandra  
Florida Solar Energy Center  
300 State Road 401  
Cape Canaveral, FL 32920

## ACKNOWLEDGEMENTS

We appreciate the financial support of ASHRAE for funding this research. We thank Mr. William Seaton, manager of ASHRAE research for his cooperation throughout the project. We are grateful to the ASHRAE project monitoring committee--Fred Bauman, Tamami Kusuda and Chip Barnaby for their helpful advice and suggestions. We also would like to thank Bishri Abdel-Hamid and Adel Kamel for their assistance in data analysis.

Muthusamy Swami  
Subrato Chandra

## TABLE OF CONTENTS

## PART 1 - CALCULATION PROCEDURE

	Page
1.1 Introduction	... 1-1
1.2 Calculation Procedure for Determining Ventilation Rates	... 1-5
1.3 Definitions	... 1-8
1.4 Determination of Reference Velocity	... 1-9
1.5 Cp Correlations	... 1-10
1.6 Correction for Surrounding Building Effects	... 1-12
1.7 Procedure A - Ventilation Through a Single Window	... 1-15
1.8 Procedure B - Ventilation Through One Inlet and One Outlet	... 1-16
1.9 Procedure C - Ventilation Through Multiple Inlets and Outlets	... 1-17
References	... 1-19
Tables	... 1-20
Figures	... 1-21

## PART 2 - BACKGROUND AND DATA ANALYSIS

2.1 Approach to Cp Data Reduction for Low-rise Buildings	... 2-1
2.2 Consolidation of Available Cp Data	... 2-8
2.3 Data Reduction for Low-rise Buildings	... 2-14
2.4 Surrounding Effects and Discharge Coefficients	... 2-18
2.5 Minimum Ventilation and Single Windows	... 2-23
2.6 Data Reduction for Tall Buildings	... 2-25
2.7 Comparison of Predicted and Measured Ventilation Rates	... 2-28
References	... 2-30
Tables	... 2-32
Figures	... 2-53

PART 1  
PROCEDURE FOR CALCULATING  
NATURAL VENTILATION AIRFLOW RATES  
IN BUILDINGS

## 1.1 INTRODUCTION

Natural ventilation through open windows in a building is an effective cooling strategy during some portions of the cooling season. To predict cooling energy savings from naturally ventilated buildings or for other design and analysis purposes, one might want to calculate hourly airflow from natural ventilation. The purpose of this document is to recommend such calculation procedures for wind driven airflows. The procedures are for calculating flows through large apertures, not for calculating infiltration airflow rates. However, the building pressure coefficient database developed in this report can be very useful for calculating infiltration airflows also. Airflows through open windows in a building arise out of interactions of the building and the wind. A knowledge of Building pressure distributions arising out of building and wind interactions is central to airflow calculations. The analyst should be familiar with Chapter 14 of the 1985 ASHRAE Handbook of Fundamentals which contains the basics of airflow around buildings before proceeding with the calculations.

Much building pressure data is available worldwide, primarily obtained by the civil engineering community for determining wind loads, and is expressed in the form of a pressure coefficient  $C_p$  defined as:

$$C_p = \frac{P - P_r}{1/2 \rho V_{ref}^2}$$

where

$p$  = local building pressure measured by a pressure tap flush with the building surface

$P_r$  = reference free stream static pressure

$V_{ref}$  = reference wind speed at a reference height above ground

$\rho$  = air density

The Cp data has been largely collected by wind engineers using boundary layer wind tunnels (where the natural variation of wind speed with height above ground is correctly simulated) to obtain data on scale models of solid (i.e. non porous) buildings. Recent research (Vickery, 1983, see summary in Chandra et. al. 1986) found that solid body Cp data can be used to calculate airflow rates through ventilated buildings if a simple correction was made (described later). Thus large body of available Cp data on solid models can be used for ventilation calculation through apertures in building walls. Note that Vickery found flow through building apertures at roof peaks cannot be accurately predicted from solid body Cp. Such apertures are only rarely used in building ventilation. The procedure in this report are valid only for apertures (i.e. windows) in walls.

### Limitations of the Proposed Procedure

The proposed procedure uses Cp data from a variety of sources. All sources give data for simple rectangular planforms. It will probably be correct to state that over 90% of single family detached housing in the U.S. is not a simple rectangle but is L shaped or U shaped or is even more complex due to presence of garages porches etc. Realizing this, we have given engineering suggestions for how to compute wall average Cp's for these popular plan shapes. It must be stated again that these are estimates based on educated guesswork. Systematic wind tunnel experiments must be conducted on L, U and other planforms of practical interest to accurately analyse these cases.

Another area where data is inadequate is in the area of roof slopes. Only a few studies have data on models with various roof slopes. In our data analysis we found no systematic effect of roof slope and so the recommended correlation does not have roof slope as a variable. However, one study did systematically study effect of roof slope. This data got diluted by other studies with random roof slopes and so roof slope does not appear as a statistically significant parameter. Additional research on this topic is desirable. We summarize below the range of building geometries from which the data was developed.

#### LOW RISE: Planform - rectangular

- 1 <= long to short wall ratio <= 8
- 0.1 <= eave height to short wall ratio <= 0.4  
(typical of 1 to 2 storey)
- 0 <= over hang/eave height <= 0.2
- 0 <= roof angle <= 60 deg

#### HIGH RISE: Planform - rectangular

- 1 <= long to short wall ratio <= 4
- 1 <= eave height to short wall ratio <= 8
- over hang = none
- roof angle = 0



Further details and drawings of building models tested may be found in part 2 .

We do not recommend the use of the  $C_p$  correlations to buildings whose geometrical parameters fall outside of the ranges specified above.

Before proceeding further we will note the other assumptions and uncertainties that exist in the recommended calculation procedure:

1. No stack effect. Stack effects are usually weak in well ventilated buildings. If the stack effect is expected to be substantial (e.g. due to an external chimney) one can combine the stack and wind driven airflows per procedures given in ASHRAE, 1985 Handbook of Fundamentals (pp. 22.4-22.7)
2. No pressure drop inside building, negligible effects due to partitions. These are perhaps reasonable assumptions for well ventilated buildings. However no data exists on this topic.
3. Perfect Mixing. This is not really pertinent to the calculation of airflow. However if one chooses to use the computed airflow in a heat removal equation, an assumption on mixing needs to be made. Usually the perfect mixing assumption is made. Currently, ASHRAE is seeking to obtain data on this topic under its research project 529-TRP.
4. Airflow is due to mean pressure difference alone and fluctuating pressure effects are ignored. This is a reasonable assumption at high flow rates (10 ach and above). For low wind speeds, fluctuating pressures can cause airflow greater than that would be predicted by the procedures. We do present a recommendation on minimum air change (described later).
5. Use of meteorological wind data. Meteorological wind data is generally recorded in flat terrains (e.g. airports) and reported on an hourly average basis. During the hour, the airflow can change quite a lot. However since airflow is directly proportional to the windspeed (for a given wind direction) the calculated airflow will correspond well to the average hourly value. Greater uncertainty arises in estimating the site wind speed from available meteorological data. For this we have used wind engineering correlations developed for strong winds (e.g. >12mph). For most natural ventilation situations the wind speeds are lower than 12 mph. The extent to which the strong wind correlations hold for low winds is unknown at this time. However the only correlations available are for strong winds. We have chosen to recommend the power law equations over the log law to describe the wind profile. Either representation in low wind-speed and in presence of nearby obstructions is at best approximate.

However we chose to recommend the power law as it is widely used for infiltration calculations (e.g. Sherman and Grimsrud, 1982).

6. Use of  $C_p$  data on a wall average basis for low-rise buildings. Although the  $C_p$  can vary widely over a building face, the strongest variations are near the edges of the face. Windows are seldom placed near building edges. We found (see part 2) that for typical residences, airflow rates can be predicted with little loss of accuracy and with considerable increase in ease of use if wall average  $C_p$  was used instead of local  $C_p$ .
7. Valid for window or other wall apertures only; not for roof level apertures.

Airflows may need to be calculated for many different types of buildings or situations. Section 1.2 presents the overall procedure which should be the starting point for the calculation. Figure 1-1 presents a flowchart of different paths to take for analyzing a specific building. Please note that figures for part 1 begin on page 1-21.

## 1.2 CALCULATION PROCEDURE FOR DETERMINING VENTILATION RATES

This section gives the steps to be followed in order to calculate ventilation air flows for a specific building. The reader should refer to Figure 1-1 for a flow chart of the steps necessary. Section 1.3 provides a list of definitions for easy reference.

STEP 1: Get wind, building and terrain data. The following data should be known in this step.

### Terrain data:

- h : mast height in the reference terrain.  
user units (ft or m)
- $V_{rh}$  : wind speed in the reference terrain  
at height h, user units
- $a_r$  &  $b_r$  : Terrain constants of the reference  
terrain (See Table 1-1)
- $a_b$  &  $b_b$  : terrain constants of the building  
terrain (See Table 1-1)

### Building data

- L : Building Length
- W : Building width
- H : Reference height.  
= Average window height for tall buildings  
= Eave height for low rise buildings  
(up to 3 stories)

### Window parameters

- $A_i$  : Area of the ith window.  
It is defined as the open window area. For sliding or hung windows, open window area is typically 40% of the rough opening in the wall. For fully operable windows (e.g. awnings or casement windows) assume  $A_i$  to be the entire glazed area. See Figure 1-2 for a drawing of various window types. The window may or may not have insect screening. Correction factors for insect screening or awning window blockage when open are given later in Step 6 of this section.
- XL and ZH : the horizontal and vertical location  
of each window on the wall. (required  
for tall buildings only - see Fig 1-3  
and definitions)

STEP 2: Using H as the reference height calculate the reference velocity ( $V_{ref}$ ) at this reference height using procedure outlined in Section 1.4.

STEP 3: Choose one of the following.

- o If all windows are on a single wall, determine the total window area (A). Go to Step 4.
- o If low-rise building then:
  - i) Sum window areas on each wall and treat them as single windows.
  - ii) Use equation 1.5.1 in Section 1.5 to determine  $C_p$  for each wall.
  - iii) Use Section 1.6 to modify/correct the  $C_p$ s for surrounding and other effects.
- o If high-rise buildings: Use equation 1.5.2 of Section 1.5 to determine  $C_p$  for each window location.

STEP 4: Choose one of the following:

- o Use procedure A outlined in Section 1.7 for single windows
- o Use procedure B outlined in Section 1.8 for one window each on two walls
- o Use procedure C outlined in Section 1.9 for windows on three or more walls

Step 5: Choose one of the following

- o If procedure A was used in step 4, ignore this step.
- o If procedure B or C was used apply the following correction to account for window aperture.

$$C_a = C_Q / (1 + C_Q)$$

where  $C_a$  - is the actual flow coefficient and  
 $C_Q$  - is the flow coefficient calculated  
in procedures B or C

Calculate airflow as:

$$Q = C_a V_{ref} A_e$$

STEP 6: Correct for window type and insect screening by multiplying the flow by the following factors.

- o Fully open awning window, no screen: 0.75

- o Awning window and 60% porosity insect screen: 0.65
- o 60% porosity insect screening: 0.85
- o No data available for blockage in casement windows when the winds are at an oblique angle.

Step 7: Calculate ACH.

$$\text{ACH} = \frac{Q}{\text{zone volume}}$$

Step 8: Apply correction for surrounding effects to the flow from Section 1.6 (subsection 4, p. 1-13) if no other surrounding effects were not accounted for earlier.

If ACH is less than 3 use ACH = 3.

### 1.3 DEFINITIONS

The definitions of the various parameters used in the calculation procedure are summarized here. For a more detailed understanding the reader is referred to Part 2 of this report.

- o WIND ANGLE (AS): The angle between the wind direction and the outward normal of the wall under consideration. (See Fig 1-4)
- o SIDE RATIO (S): The ratio of the width of the wall under consideration to the width of the adjacent wall. (See Fig 1-4)
- o OBSTRUCTION ANGLE (AW): The smaller of the angle (in degrees) made by the line joining the centers of a single neighboring building and the building under consideration and the wind direction. (See Figure 1-5d)
- o SPACING FACTOR (SF): The ratio of the distance of the neighboring building to the length of the house under consideration. (See Fig 1-5c)
- o RECTANGULAR PATTERN: The surrounding pattern similar to the one shown in Figure 1-5a.
- o HEXAGONAL PATTERN: The surrounding pattern similar to the one shown in Figure 1-5b.
- o EFFECTIVE AREA ( $A_e$ ): Effective window area. Definition differs for different cases. For buildings with windows on only one wall or windows on 3 (three) or more walls  $A_e$  = sum of all window areas. For problems with windows on two walls see Section 1.8.
- o TERRAIN CONSTANTS (a's and b's) : The values of a's and b's chosen from Table 1-1 which define the terrain characteristics.
- o LENGTH RATIO (XL): The horizontal location of a point on a wall and is the ratio of the horizontal distance (X) of the point from the edge of the wall to the length (L) of the wall (See Fig 1-3).
- o HEIGHT RATIO (ZH): The vertical location of a point on a wall. It is defined as the ratio of the distance (Z) of the point from the ground to the height (H) of the wall (See Fig 1-3).

#### 1.4 DETERMINATION OF REFERENCE VELOCITY

The steps to be followed in order to calculate the reference velocity in the building terrain at any specified height is given here.

The following data must be known

Reference terrain parameters:-

- h : mast height in the reference terrain.
- V<sub>rh</sub> : wind speed in the reference terrain at height h
- a<sub>r</sub> & b<sub>r</sub> : Terrain constants of the reference terrain  
(Table 1-1, p. 1-20)

Building terrain parameters:-

- H : height in building terrain where V<sub>ref</sub> is required.
- a<sub>b</sub> & b<sub>b</sub> : terrain constants of the building terrain (Table 1-1)

To determine :-

V<sub>ref</sub> = V<sub>bH</sub> : The reference Velocity at the height (H) in the building terrain. This is the Reference velocity that has to be determined and used in the calculation procedure.

Use the following equation if h, H are in meters.

$$V_{ref} = V_{bH} = [(10/h)^{b_r}] * [(H/10)^{b_b}] * (a_b/a_r) * V_{rh} \quad \dots 1.4.1$$

V<sub>ref</sub> is the reference velocity to be used in the calculation procedure.

NOTE: Equation 1.4.1 is valid only if the units H,h are in meters. If the units of feet are used for H and h, the equation must be modified as follows:

$$V_{ref} = V_{bH} = [(33/h)^{b_r}] * [(H/33)^{b_b}] * (a_b/a_r) * V_{rh} \quad \dots 1.4.1a$$

## 1.5 CP CORRELATIONS

This section gives the equations for  $C_p$  obtained through curve fit of experimental data collected from different sources. Two sets of equations, one for low-rise buildings and another for tall buildings are given.

### LOW-RISE BUILDING

Before using the equations, the dependent parameters will have to be determined:

1. For each wall determine the appropriate side ratio ( $S$ ) according to definitions.
2. For each wall determine the wind incidence angle ( $AS$ ) according to definition.
3. Use the following equation to calculate the normalized  $C_p$  ( $NC_p$ ) for each wall.

$$NC_p = \ln(C_0 + C_1 \cdot \sin(AS/2) + C_2 \cdot \sin^2(AS) + C_3 \cdot \sin^3(2 \cdot AS \cdot G) + C_4 \cdot \cos(AS/2) + C_5 \cdot G^2 \cdot \sin^2(AS/2) + C_6 \cdot \cos^2(AS/2)) \quad \dots 1.5.1$$

Where:

$NC_p$  is the normalized  $C_p$   
 $\ln$  denotes the natural logarithm  
 $AS$  is the wind angle  
 $G = \ln(S)$  (natural log of the side ratio  $S$ )

The coefficients of the equation are:

$$\begin{array}{ll} C_0 = 1.248 & C_1 = -0.703 \\ C_2 = -1.175 & C_3 = 0.131 \\ C_4 = 0.769 & C_5 = 0.071 \\ C_6 = 0.717 & \end{array}$$

4. From the normalized  $C_p$  value calculate the actual  $C_p$  by multiplying the normalized value by the  $C_p$  at zero incidence for that wall. Use  $C_p$  at zero incidence to be 0.6.
5. If a garage or wingwall is present on a wall modify  $C_p$  for that wall as illustrated in Figure 1-6.
6. If the house is U-shaped modify  $C_p$  for the inner walls of the U as illustrated in Figure 1-7.

Note that all data in literature is for rectangular buildings. Steps 5 and 6 above are authors' recommendation on what do for realistic house plans.



## HIGH-RISE BUILDING

1. For each window, determine its location in terms of XL and ZH and the applicable side ratio (S) according to definitions.
2. For each window determine the wind incidence angle (AS) according to definition.
3. Use the following equation to calculate the actual Cp for each window.

$$C_p = C_0 + C_1 \cdot A_r + C_2 \cdot \cos(2 \cdot A_S) + C_3 \cdot Z_H \cdot \sin(A_S) \cdot S^{0.169} + C_4 \cdot \cos(A \cdot A_S) \cdot S^{0.279} + C_5 \cdot \sin(2 \cdot A_S) + C_6 \cdot Z_H \cdot \cos(A_S) + C_7 \cdot \cos(X_r) + C_8 \cdot \cos(X_r \cdot A_S) + C_9 \cdot \cos(X_r \cdot A_S) \cdot S^{0.245} + C_{10} \cdot Z_H \cdot \sin(A_S) + C_{11} \cdot X_r \cdot \sin(A_S) + C_{12} \cdot X_L + C_{13} \cdot \cos(X_r) \cdot S^{0.85} \quad \dots 1.5.2$$

Where

$$A_r = A_S \cdot 3.1415 / 180 \quad (\text{wind angle in radians})$$

$$X_r = (X_L - 0.5) / 0.5$$

and

$A_S$ ,  $S$ ,  $X_L$  and  $Z_H$  have their usual meaning  
(See definition in Section 1.3)

The coefficients of the equation are:

$C_0 = 0.068$	$C_1 = -0.839$
$C_2 = 1.733$	$C_3 = -1.556$
$C_4 = -0.922$	$C_5 = 0.344$
$C_6 = -0.801$	$C_7 = 1.118$
$C_8 = -0.961$	$C_9 = 0.691$
$C_{10} = 2.515$	$C_{11} = 0.399$
$C_{12} = -0.431$	$C_{13} = 0.046$

## 1.6 CORRECTIONS FOR SURROUNDING BUILDING EFFECTS

This section gives the necessary correction and modification to be made to the  $C_p$  data for surrounding and other effects.

Determine the surrounding effect that closely matches the building under consideration from Figure 1-5 (a,b or c). Ignore this step and go to Step 4 if surroundings are not close to any of the patterns in Figure 1-5. In steps 1 to 3 below equations for AD are given. AD should be applied to  $C_p$  as follows :

$$C_p(\text{in presence of surrounding building}) = AD + C_p(\text{unobstructed building})$$

1. If the rectangular surrounding pattern is applicable, use the following equation to get the correction for  $C_p$  for each wall:

$$AD = 1.26*(A_0 + A_1*AN + A_2*AN^2 + A_3*AN^3 + A_4*AN^4) \quad \dots 1.6.1$$

Where AD : is the change in  $C_p$  due to this surrounding pattern  
 AN : Wind angle/180.00 = AS/180.0

The coefficients of the equation are:

$$\begin{aligned} A_0 &= -0.309 \\ A_1 &= -1.061 \\ A_2 &= 12.304 \\ A_3 &= -20.490 \\ A_4 &= 9.766 \end{aligned}$$

2. If the hexagonal pattern is applicable, use the following equation to get the correction for  $C_p$  for each wall:

$$AD = 1.26*(A_0 + A_1*AN + A_2*AN^2 + A_3*AN^3 + A_4*AN^4) \quad \dots 1.6.2$$

Where AD : is the change in  $C_p$  due to this surrounding pattern  
 AN : Wind angle/180.00 = AS/180.0

The coefficient of the equation are:

$$\begin{aligned} A_0 &= -0.230 \\ A_1 &= -1.004 \\ A_2 &= 9.253 \\ A_3 &= -14.119 \\ A_4 &= 6.240 \end{aligned}$$

3. If a single neighboring building is present, then calculate the spacing factor (SF), obstruction angle (AW) for each wall. Use the following equation for correcting  $C_p$ s for each wall.

$$AD = 1.26 * EXP(-3 * AR) * \{ A1 * SIN(AS - 47.0) / SF + A2 * [SIN(AS - 47.0) / SF]^2 + A3 * [SIN(AS - 47.0) / SF]^3 \} \dots 1.6.3$$

Where AD : is the Cp difference  
 AR :  $AW * 3.1415 / 180.0$  (obstruction angle in radians)  
 SF : spacing factor (see definition section 1.3)  
 AS : wind angle (in degrees)

The coefficient of the equation are:

$$\begin{aligned} A1 &= 1.039 \\ A2 &= -0.0476 \\ A3 &= -0.684 \end{aligned}$$

Note : If obstruction angle AW is more than  $45^\circ$ , AD may be taken to be zero without invoking the above equation .

#### 4. Correction for other surrounding effects

In cases where the surrounding pattern does not match any of the cases described above the following correction factors are suggested to the ventilation flow rate. The user must come back to this step after calculating the ventilation air flow in step 7 of the calculation procedure in Section 1.2.

The corrections are to be applied to the ventilation flowrate calculated in step 7 of the calculation procedure based on the following general shielding class in which the building is located.

Shielding Class	Correction Factor (SCF)	Description
I	1.0	No obstruction or local shielding whatsoever.
II	0.88	Light local shielding with few obstructions (e.g. a few trees or a shed in the vicinity).
III	0.74	Moderate local shielding; some obstructions within two house heights ( e.g. thick hedge or fence and nearby buildings).
IV	0.57	Heavy shielding; obstruction around most of perimeter building or trees within five building heights in most directions (e.g. well developed dense tract houses)

V	0.31	Very heavy shielding, large obstruction surrounding perimeter within two house heights (e.g. typical downtown area).
---	------	--

Note that these correction factors should be used only if no other corrections have been made for surrounding effects and is to be applied to the ventilation flow rate and not Cps.

$$\text{Corrected ACH} = \text{ACH} * \text{SCF}$$

## 1.7 PROCEDURE A

## VENTILATION THROUGH SINGLE WINDOW

The formula for calculating ventilation rates through a single window is given by:

$$Q = 0.05 A V_{\text{ref}}$$

where

Q - is the air flow in m<sup>3</sup>/sec

A - is the open aperture area of all windows on that wall (in m<sup>2</sup>)

V<sub>ref</sub> - is the wind speed at the building site at reference height. For low rise buildings use eave height as reference height. For high rise buildings calculate airflow separately for each floor using ceiling height of that floor as the reference height.

The reference wind speed at the site reference height can be calculated from meteorological data using the procedure outlined in Section 1.4.

## 1.8 PROCEDURE B

## VENTILATION THROUGH ONE INLET AND ONE OUTLET

The procedure for calculating the flow through a cross ventilated building with one effective inlet and one effective outlet is presented here. The procedure can be used for a low rise building having windows on two walls or for a high-rise building having one window each on two walls.

The air flow coefficient in such rooms can be expressed as

$$CQ = Q / (A_{Ve} V_{ref}) = C_d V_{ref} (\Delta C_p)^{1/2} \quad \dots 1.8.1$$

where

$CQ$  is the flow coefficient

$Q$  is the flow

$A_e$  is the effective window area

$$= A_o A_i / (A_o^2 + A_i^2)^{1/2}$$

where  $A_o$  and  $A_i$  are the open outlet and inlet areas respectively

$C_d$  is the discharge Coefficient = 0.62

$\Delta C_p$  = Pressure coefficient difference across the inlet and outlet.

## 1.9 PROCEDURE C

## VENTILATION THROUGH MULTIPLE INLETS AND OUTLETS

The calculation procedure described here uses the Vickery (1983) model. The Vickery model starts with the standard orifice flow equation through the  $i$ th aperture. Note: In this procedure, aperture means the sum of all open areas on a wall for low rise buildings or an individual window for high rise buildings.

$$Q_i = C_{d_i} A_i V_{ref} \frac{(C_{p_i} - C_{p_I})}{|C_{p_i} - C_{p_I}|^{1/2}} \quad \dots 1.9.1$$

where  $Q_i$  = Flow through the  $i$ th aperture

$C_{d_i}$  = Discharge Coefficient for the  $i$ th aperture  
= 0.62 (recommended value)

$A_i$  = Area of the  $i$ th aperture

$V_{ref}$  = Reference velocity

$C_{p_i}$  = Pressure coefficient for the  $i$ th aperture

$C_{p_I}$  = Internal pressure coefficient (unknown)

The numerator and denominator are written specifically to account for inflows and outflows. Eq 1.9.1 is nondimensionalized by  $V_{ref}$  and (effective) area  $A_e$  (where  $A_e$  is the sum of all window areas) such that Eq 1.9.1 is recast as:

$$\Delta CQ_i = C_{d_i} \frac{A_i (C_{p_i} - C_{p_I})}{A_e |C_{p_i} - C_{p_I}|^{1/2}} \quad \dots 1.9.2$$

An iterative solution (since  $C_{p_I}$  is unknown) is obtained as follows:

Step (i) Define two starting values of  $C_{p_I}$  as

$$(C_{p_I})_1 = 1/n \sum C_{p_i}, \quad n = \text{number of apertures}$$

$$(C_{p_I})_2 = (C_{p_I})_1 + .01$$

and compute the corresponding values of net inflow  $\Sigma_1$ , and  $\Sigma_2$

where, net inflow for the  $N$ th iteration,  $\Sigma_N = \sum_{i=1}^n \Delta CQ_i$

(ii) Compute a new estimate  $(Cp_I)_N$ , for the Nth iteration, from the relationship;

$$(Cp_I)_N = (Cp_I)_{N-1} + \frac{\Sigma_{N-1}}{\Sigma_{N-2} - \Sigma_{N-1}} ((Cp_I)_{N-1} - (Cp_I)_{N-2})$$

(iii) Compute the corresponding value of the net inflow,

$\Sigma_N$ , and test  $|\Sigma_N| < 10^{-4}$

YES; put  $Cp_I = (Cp_I)_N$  and compute the elemental flow coefficients  $\Delta CQ_i$

NO; return to (i)

The flow coefficient into the building can then be evaluated by summing  $\Delta CQ_i$  over all positive values while the flow through a given surface of a high rise building can be obtained by an algebraic sum over the regions comprising that surface.

$$CQ = \Sigma \Delta CQ_i \quad \text{for all positive } \Delta CQ_i$$



REFERENCES

ASHRAE Handbook of Fundamentals, 1985.

CHANDRA, S. FAIREY, P, KERESTECIOGLU, A., KAMEL, A. "Wind Tunnel and Full Scale Data on Airflows from Natural Ventilation and Ceiling Fans." ASHRAE TRANSACTIONS, Vol 92, part 2, 1986.

SHERMAN, M.H and GRIMSRUD, D.T. "Wind and Infiltration Interaction for Small Buildings." Annual Meeting of the American Society of Civil Engineers, New Orleans, LA, October 23-29, 1982.

VICKERY, B.J., BADDOUR, R.E., KARAKATSANIS, C.A. "A Study of the External Wind Pressure Distributions and Induced Internal Ventilation Flow in Low-rise Industrial and Domestic Structures." Report No. BLWT-SS2-1983, Boundary Layer Wind Tunnel Laboratory University of Western Ontario, January 1983.

Table 1-1  
Terrain parameters for standard Terrain Classes

Class	b	a	Description
I	0.10	1.30	ocean or other body of water with at least 5 km of unrestricted expanse
II	0.15	1.0	Flat terrain with some isolated obstacles.
III	0.20	.85	Rural areas with low buildings
IV	0.25	0.67	Urban, industrial or Forest areas.
V	0.35	0.47	Center of large city

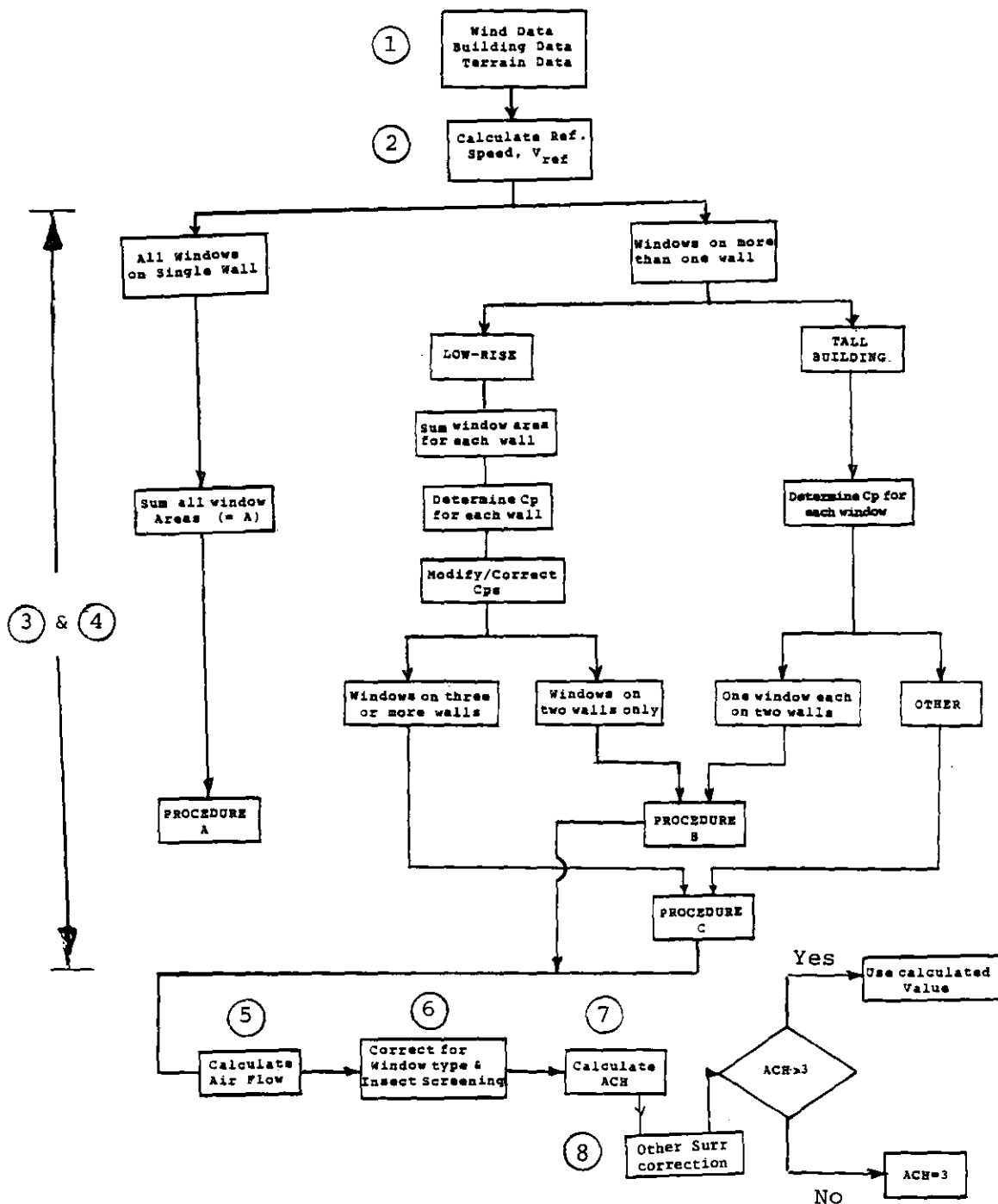

Figure 1-1 Flow Chart for Overall Procedure with Steps as Indicated in Text

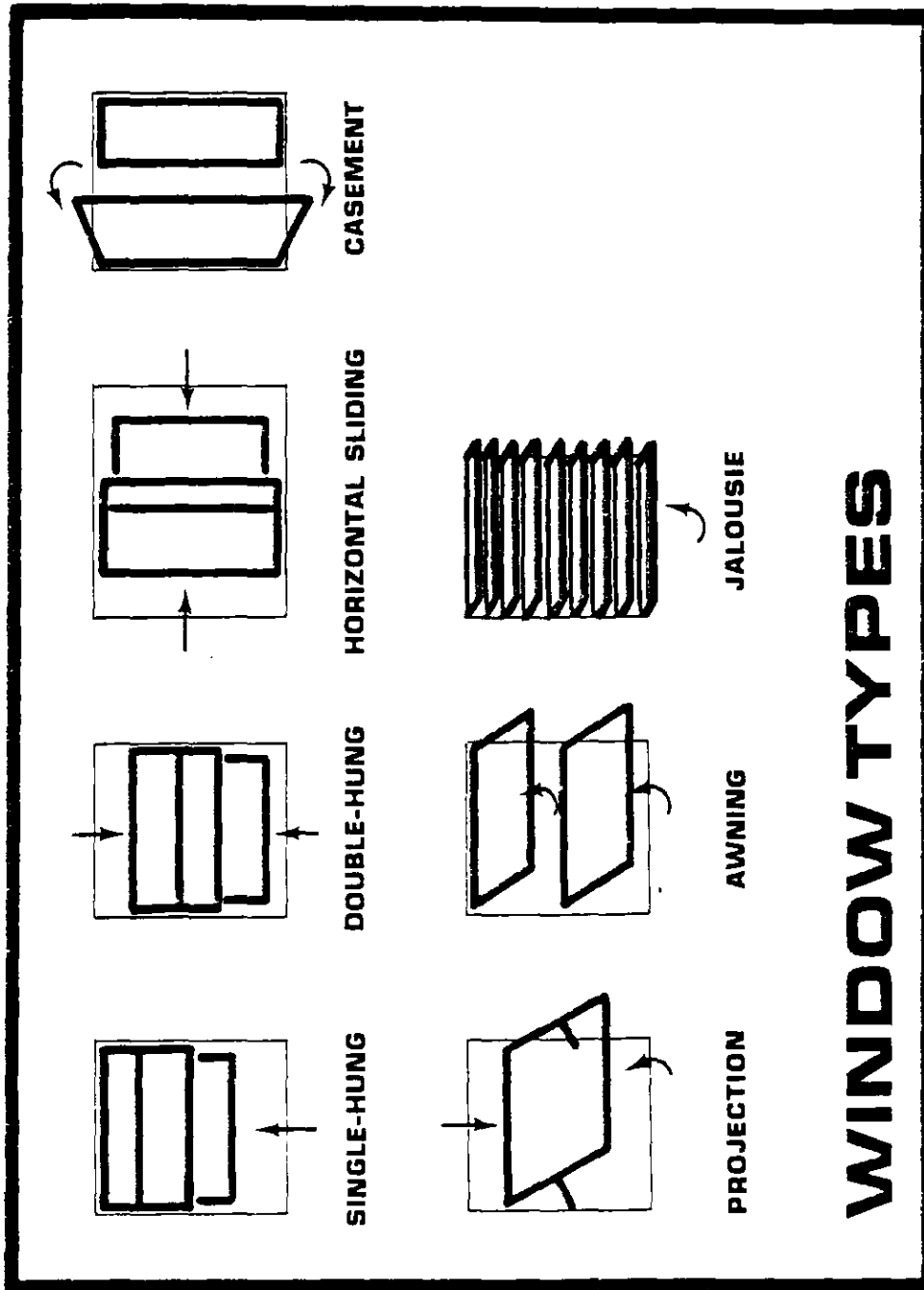
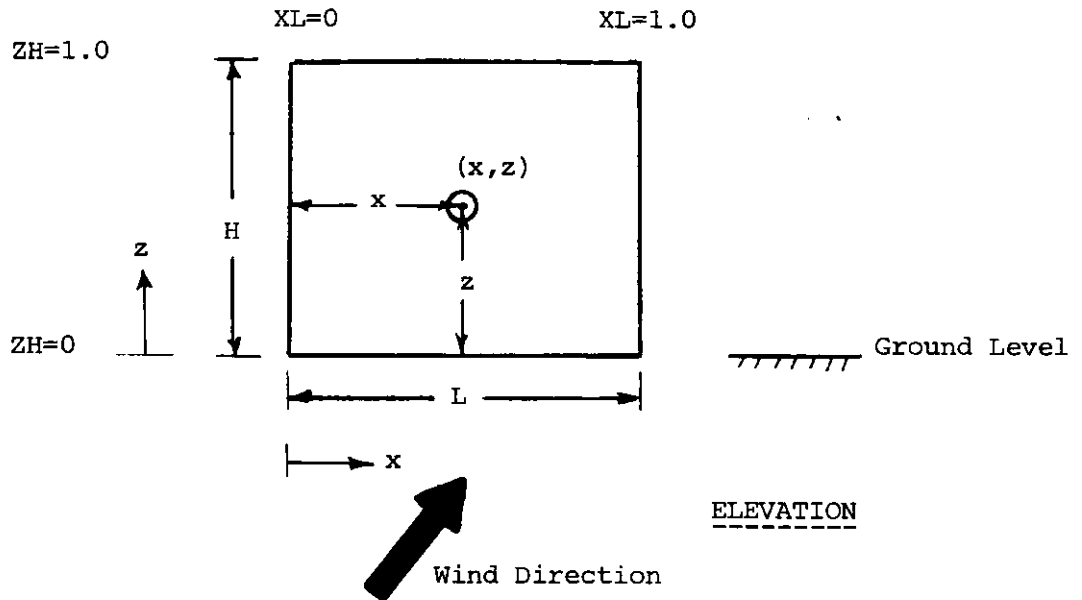

Figure 1-2



Length Ratio  $XL = x / L$   
 Height Ratio  $ZH = z / H$

- Note : (i)  $z=0$  is always the ground level  
 (ii)  $x=0$  must be always taken as the edge closer to the tail of the wind.  
 (See below)

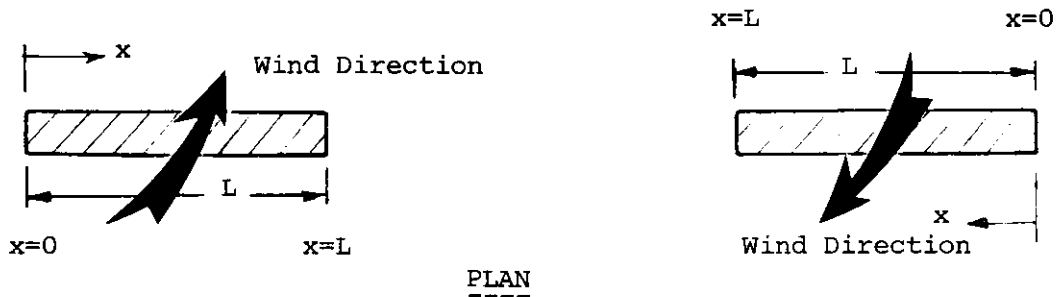
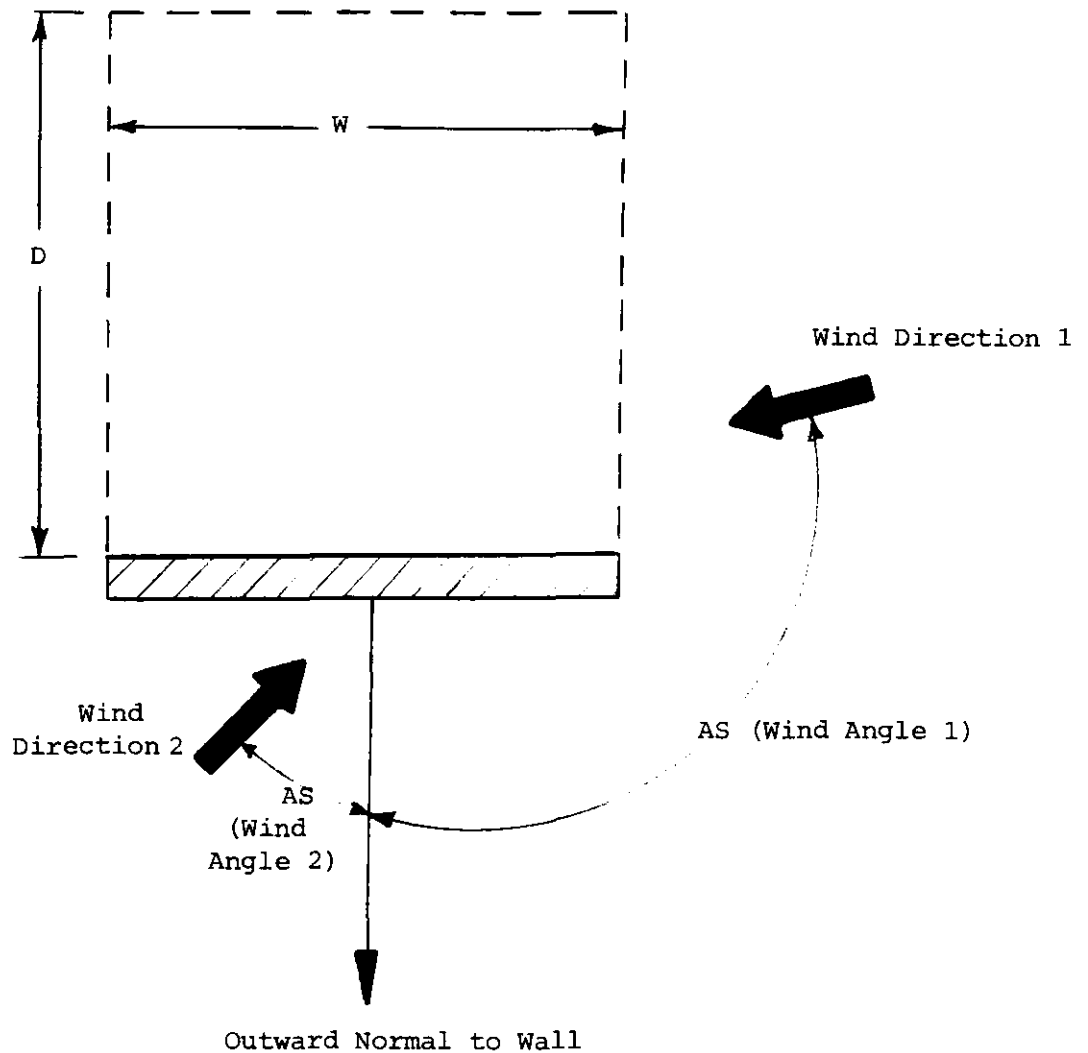
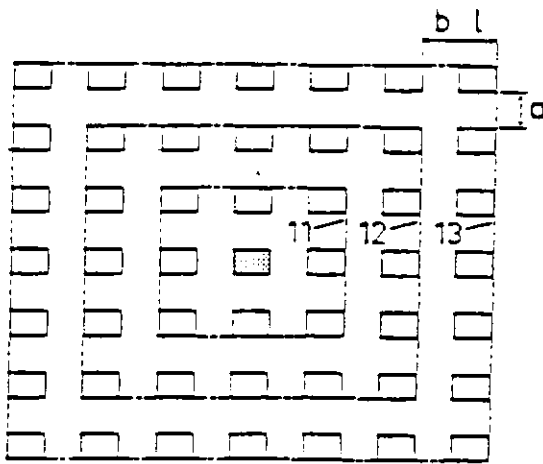

Figure 1-3 Definition of  $XL$  and  $ZH$  for Tall Buildings



AS : is the angle between the wind direction and outward normal to the wall  
 S : Side Ratio , defined as  $W/D$  where  
 W : is the width of the wall and,  
 D : is the width of the adjacent wall

Figure 1-4 Wind Angle (AS) and Side Ratio (S) Convention



Config.	$a/l = b/l$
D 11, D 12, D 13	1
F 11, F 12, F 13	1.5
H 11, H 12, H 13	2

(a) Rectangular Pattern  
From WIREN

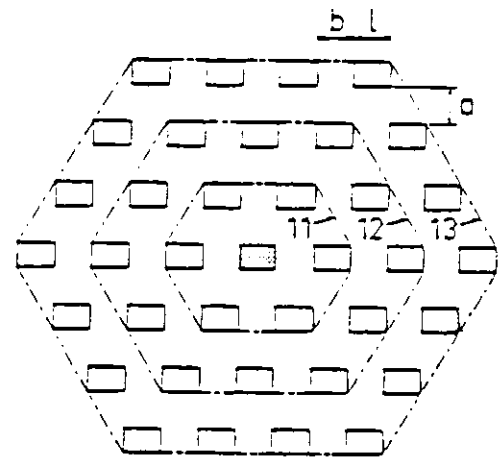

Config.	$a/l = b/l$
E 11, E 12, E 13	1
G 11, G 12, G 13	1.5
I 11, I 12, I 13	2

(b) Hexagon Arrangement  
From WIREN

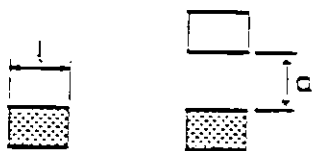

Cont: A 00 A 10, A 20, A 30, A 40

SF =  $a/l$ : — 1 1.5 2 3  
 $b/l$ : — —

Unobstructed (c) Single neighboring  
Configuration Building. From WIREN

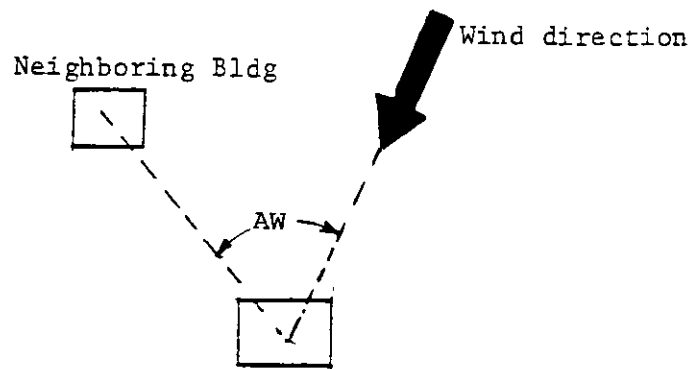

(d) Convention for angle AW

Figure 1-5 Surrounding effects and convention for obstruction angle (AW)

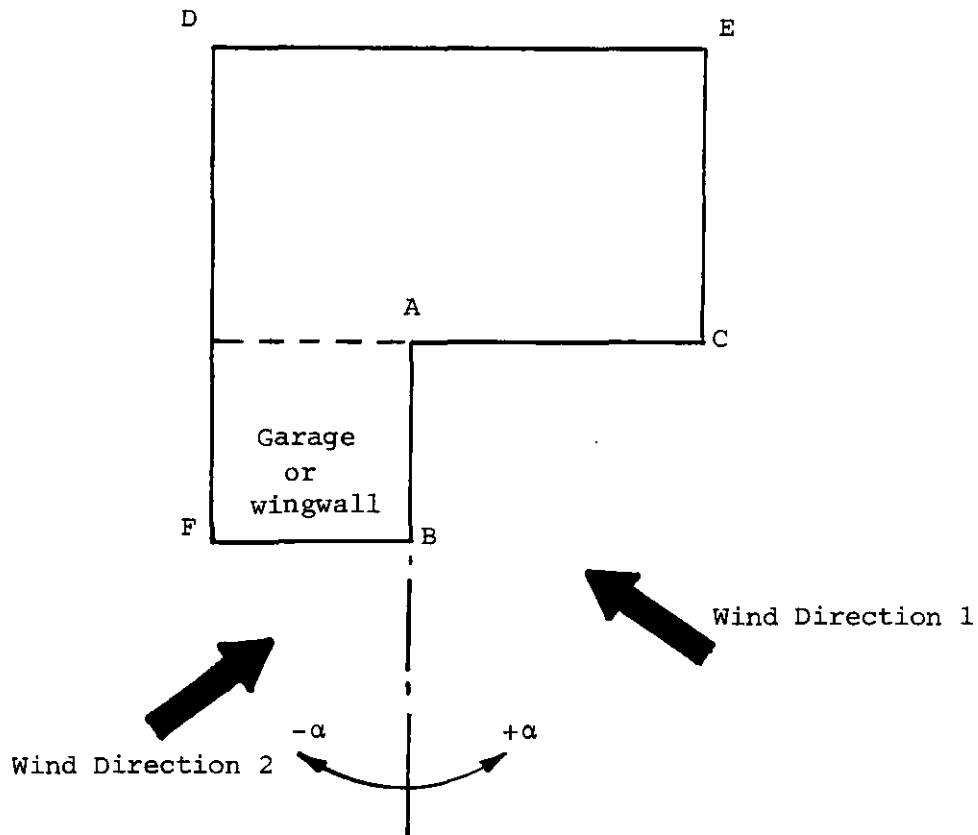

The correction/modification for wall AC should be as follows :

- i. For  $\alpha$  in the positive direction up to  $90^\circ$ ,  
Cp may be taken as the value at 0 incidence (i.e Cp=0.6)
- ii. For  $\alpha$  in the positive direction greater than  $90^\circ$ ,  
no correction is suggested.
- iii. For  $\alpha$  in the negative direction and up to  $-90^\circ$ , include  
the apertures in wall AC as if they are in Wall EC and  
use normal equations.

Figure 1-6 Correction/Modification to Cp for the Presence  
of Garage or Wingwalls



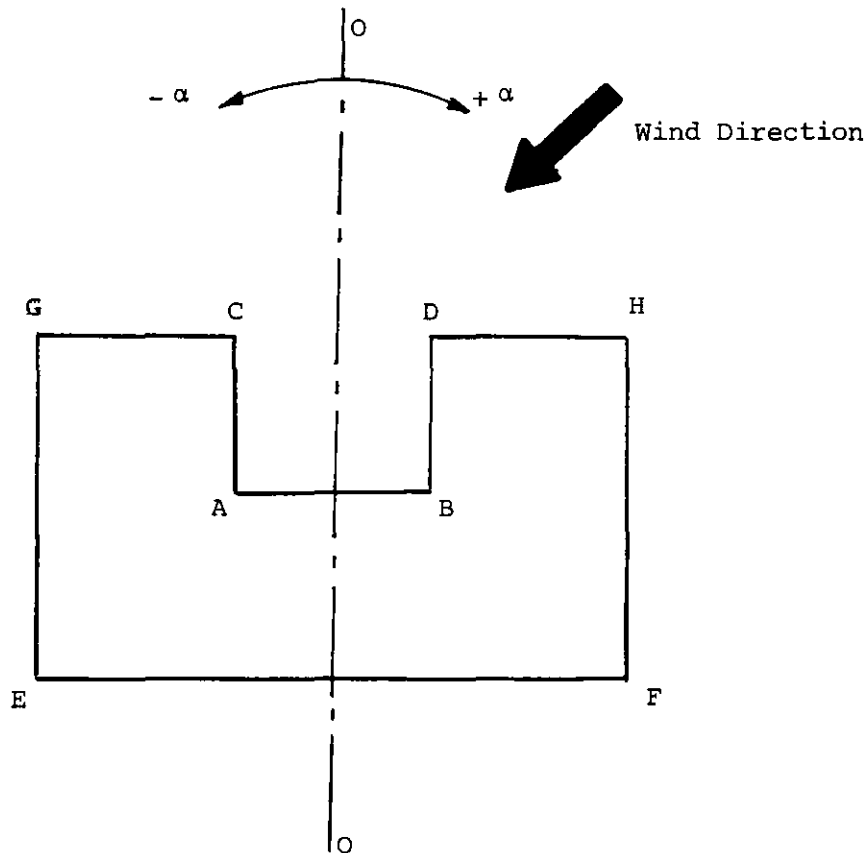

The following modification to  $C_p$ s for walls AB, AC and BD is suggested as follows :

- i. For angles  $\alpha$  up to  $\pm 45^\circ$ ,  $C_p$  for all walls AB, AC and BD may be assumed to be the value at zero incidence (i.e.  $C_p = 0.6$ ) .
- ii. For positive  $\alpha$  up to  $60^\circ$ , walls AB and AC may be taken to be at zero incidence (i.e.  $C_p=0.6$ ). Window(s) in wall BD may be added to those in wall EF .
- iii. For negative angle  $\alpha$  up to  $60^\circ$ . walls DB and AB may be taken to be at 0 incidence (i.e.  $C_p=0.6$ ). Window(s) in AC may be added to those in wall EF .
- iv. For angle  $\alpha$  beyond  $\pm 60^\circ$ , the apertures in all three walls should be treated as if they are in leeward region. Thus, add all the aperture areas in walls AC, AB and BD and include them as areas in wall GE for  $\alpha > + 60^\circ$ , and in wall HF for  $\alpha < - 60^\circ$ .

Figure 1-7 Modification to  $C_p$  for U-Shaped Building

PART 2  
BACKGROUND AND DATA ANALYSIS



## 2.1 APPROACH TO CP DATA REDUCTION FOR LOW-RISE BUILDINGS

### INTRODUCTION

The pressure coefficient ( $C_p$ ) is an important parameter required in determining ventilation rates in buildings. Many parameters such as building geometry, terrain, etc., influence the value of  $C_p$ . Not all parameters have been thoroughly examined in the literature and consequently  $C_p$  data available in the literature to perform a complete parametric analysis can at best be described as fair. However until such time as more complete data is available, simplification, modifications, and assumptions have to be made in order to get useful results from existing data and this is the aim of this study. The approaches used in order to get the available data in a form tangible for curve fitting is described in this section together with the justification for the simplifications and assumptions used.

### $C_p$ SIMPLIFICATION - SURFACE AVERAGES

The calculation procedure to be used in determining the ventilation rates for a building has been discussed in Part 1 of this report. But the major parameter required is the coefficient of pressure ( $C_p$ ). The coefficient of pressure over a building surface will vary with the position on the surface particularly near the edges. However, such data is extremely voluminous and intractable. Moreover windows are seldom located at wall edges. A logical simplification is to use the average surface  $C_p$  for the wall under consideration. In order to examine the accuracy of using average  $C_p$ s rather than local values, a comparison of ventilation rates was undertaken to see the error involved in using average  $C_p$ s rather than local  $C_p$ s for low-rise buildings.

A 1500 SF garage-less house with twelve windows was considered for the purpose of comparison. Figure 2-1 (figures for part 2 begin on p. 2-53) is a plan view of the house showing the area and location of each window. Relevant building data follows.

Building Characteristics:

- o Single story slab on grade
- o Open plan
- o Side ratio (1.0:1.6) (30' X 50')
- o Major axis east-west
- o Eaves height 8 ft
- o Long wall to eave height ratio = 6.25:1

Window glass:

- o 214 SF ( approx 14% gross floor area)
- o All windows, except south sliding window, single hung top fixed.
- o South sliding window opens right half when viewed from outside
- o Effective area multiplier for all windows 0.4 (i.e. aperture/total area)

Glass area

- o North 60 sf
- o South 70 sf
- o East 42 sf
- o West 42 sf

Roof

- o Type hipped
- o Slope 5:12 (22.6 deg)
- o Roof overhang 2 ft on all sides

Once the base building was chosen, the next task was to look for pressure coefficient data from models closest to the building chosen. Data for analysis were taken from Vickery (1983). The Vickery model which came closest to the base building chosen had the following characteristics. Cp data from this model was taken for the analysis.

Floor size 80 X 125 ft (Side ratio 1.0:1.563)

Eaves height 24 ft

Long wall to eave height ratio = 5.2:1

Roof slope 4:12

A sample of the Cp data from Vickery is reproduced in Figure 2-2. Surfaces 1 and 3 have 18 data points (6 X 3 grid) and surfaces 2 and 4 have 9 data points (3 X 3 grid). These data points are actually averages of local Cp over that grid and were reproduced as grid averages by Vickery. These data points were assumed to represent the center of the grid shown in the figure. For this particular model, Vickery has data for 3 incidence angles and two terrains, giving a total of 6 cases for comparison.

In order to calculate the local Cp for each window on the building, the data required are the location of the window on the wall and the Cp distribution for the surface considered. The locations of the windows were taken at the center of the open area of the window and the coordinates were specified with respect to the bottom left corner of the wall as viewed from outside. The local Cps were then calculated by interpolating the available Cp data from the model. However, no extrapolation were done. The following example will serve to clarify the procedure followed.

Consider the Cp data for surface 1 for the case 80:125:24 for open terrain and for an incidence angle of 0 degrees. The data should be seen for the surface as viewed from outside as shown below. In addition to the size of the surface, the coordinates of the data points with respect to the bottom left hand corner is also shown.

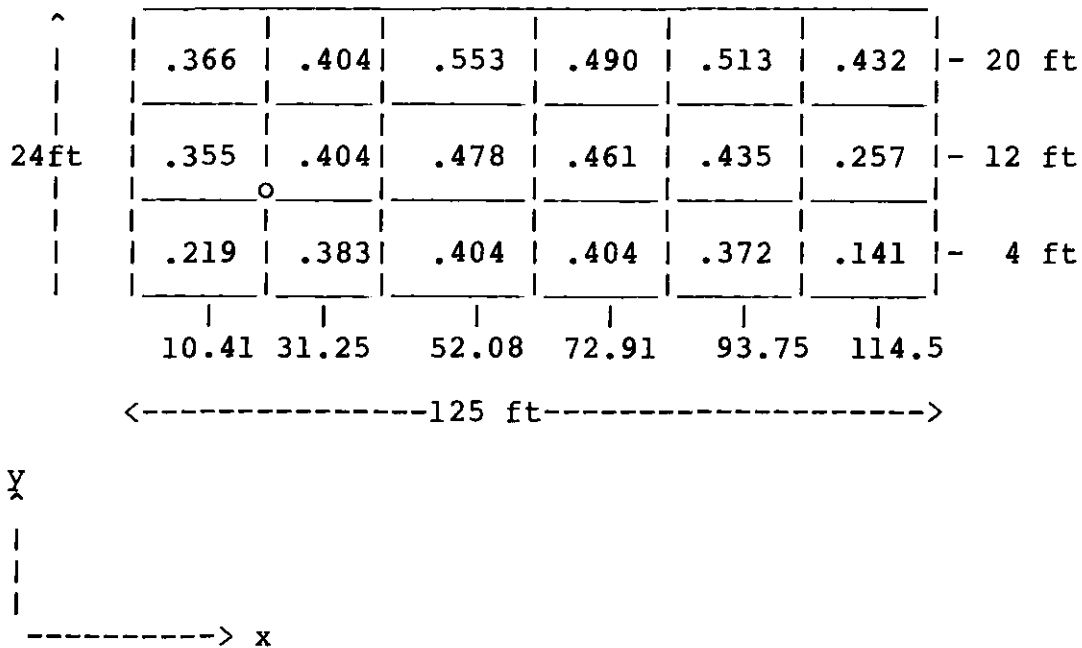

As an example, let us calculate the local  $C_p$  for the 14 SF window on the south wall (50' X 8') of the building. The center of the opening of the window is located at 8 ft horizontally and 3.25 ft vertically from the bottom left corner. The x and y location of the window opening scaled to the model size would be:

$$X \text{ location} = 8 \times 125/50 = 20.00 \text{ ft}$$

$$Y \text{ location} = 3.25 \times 24/8 = 9.75 \text{ ft}$$

As can be seen from above, the window location would fall on the surface shown by o and bounded by four  $C_p$  values, .219, .383, .355 and .404

Interpolating horizontally twice

$$\begin{aligned} C_{ph1} &= .219 + (.383 - .219)(20 - 10.41)/(31.25 - 10.41) \\ &= .29444 \end{aligned}$$

$$\begin{aligned} C_{ph2} &= .355 + (.404 - .355)(20 - 10.41)/(31.25 - 10.41) \\ &= .37754 \end{aligned}$$

Now interpolating vertically for the local value

$$\begin{aligned} C_{pl} &= .29444 + (.37754 - .29444)(9.75 - 4)/(12 - 4) \\ &= 0.3542 \end{aligned}$$

However, in cases where the location was not bounded by available Cp data, interpolation was carried out only between available data points and no extrapolation was carried out. For example, if the window location fell on the border of the surface, interpolation was carried out only in the direction where the location fell between two points where Cps are known. If the location fell in the corners, the measured data nearest to the corner was taken to represent the local Cp value.

The procedure for calculation of ventilation rates through the building was taken from Vickery (1983). The details of the procedure is given earlier in Part 1. The south wall was taken as surface 1 for the purpose of the analysis.

Calculation of the ventilation rates using the above procedure were carried out for two terrains and three incidence angles. Ventilation rates were calculated considering both interpolated local Cp values as well as average values over each surface. In addition, the following assumptions were made:

Wind speed at Eave height	= 5 miles/hr
Discharge coefficient for all windows	= 0.62
Convergence tolerance	= .00001

The summary of results of the calculations are shown in Table 2-1 (tables begin on p. 2-32). Examination of the table reveals that there is excellent agreement in all but one case. Closer examination of the Vickery data for that case revealed that the data on the leeward wall is suspect. One expects that for 90 degree of incidence the Cp data on surface 4 would be symmetric about the centerline. However, the real data is highly asymmetric. This indicates a data problem.

In an earlier conversation, Vickery pointed out the difficulty of measuring small pressures in the wind tunnel. The suburban profile has a higher velocity defect than the open terrain profile (i.e. the open terrain profile is fuller; see Figure 2-3). This causes lower pressure differences wrt static tap particularly on leeward sides and thus increases measurement uncertainty. Unfortunately, we will have to live with this. Using average surface data will actually lessen these types of problems (i.e. one or two local Cp data error will not affect the surface average data too much). It seems reasonable to conclude from this effort that average wall surface Cp are legitimate to use. This will of course simplify data reporting and increase user friendliness of design procedures.

#### TERRAIN SIMPLIFICATION

The terrain where a building is located is another important parameter determining the natural ventilation through the building ventilation. The terrain mainly effects the velocity profile of the wind at a particular location. Few researchers have carried out tests involving terrain as a parameter for low



rise buildings and ,therefore, it is impossible to categorize terrain dependence of  $C_p$  with a good degree certainty with the data available in the literature. Therefore, simplifications required to eliminate terrain from the  $C_p$  data was further looked into. Akins [1976] in his wind tunnel study of tall buildings found that the dependence of  $C_p$  on the terrain virtually vanishes if the  $C_p$  is calculated with respect to the local height of measurement rather than at some fixed height. For low rise buildings the data from Vickery is compared in Figure 2-4. The figure shows the wall average  $C_p$  for suburban terrain plotted against the data for open terrain without any other adjustment. It might be tempting to conclude from data in Figure 2-4 that in suburban terrain, all else being equal,  $C_p$  values decrease by 15% to 20%. However, other data sources (e.g. Jensen, 1965) indicate that  $C_p$  increases as the turbulence level increases. Thus we conclude, in view of available sparse and conflicting data, that  $C_p$  dependence on terrain is negligible. Of course the terrain effect will come into play when calculating the reference velocity as detailed in part 1, Section 1.4.

#### WIND ANGLE AND BUILDING GEOMETRY

The coefficient of pressure varies considerably with the approach wind angle and to a lesser extent with the geometry of the building (that is the side ratio and roof slopes).

$C_p$  data, either mean or local, are usually given in terms of the wind angle for each of the four surfaces constituting the house. Since all data available are for rectangular buildings and are symmetric (or nearly so), the wall number can be eliminated as a variable by redefining the wind angle. The wind angle is defined to be the angle between the outward normal of a surface and the wind. It is always a positive value between 0 and 180 degrees. This is illustrated in Figure 2-5. Due to the symmetry of the data, the actual sign of the angle is unimportant. The solid line in the figure is the wall surface under consideration and the dotted line indicates the rest of the building. Since the dimension of the adjacent wall will influence the pressure coefficient of the wall, the  $C_p$  at a point on the wall will be a function of the wind angle and the dimension of the adjacent wall. To account for the dimension of the adjacent wall, a parameter  $S$  ( $=W/D$  see Fig 2-5) is defined and is another parameter influencing the  $C_p$  value.

Data for all the surfaces were converted into this form. The following illustration will serve to clarify the convention. The first set of data from Vickery is used for this purpose (see Fig 2-2 for surface numbers)

Vickery data:

Angle	surf 1	surf 2	surf 3	surf 4
AZ=00	, 0.396,	-0.461,	-0.355,	-0.461
AZ=45	, 0.171,	0.121,	-0.339,	-0.332
AZ=90	, -0.233,	0.226,	-0.174,	-0.213

Note that the value of S for surfaces 1 and 3 is  $125/80 = 1.56$  and for surfaces 2 and 4 is  $80/125 = 0.64$ .

Two sets of data will then arise, one for  $S=0.64$  and one for  $S=1.56$

The converted data will be as follows:

Angle	S=1.56	S=0.64
0	.396	.226
45	.171	.121
90	-.233 or -.174	-.461
135	.339	-.332
180	-.355	-.213

As seen above, the surface numbers have been eliminated and the Cps have been converted so as to depend on the wind angle with respect to the particular surface under consideration only. This will result in considerable simplification during computer implementation. The above data can now be curve fitted in terms of wind angle and S. In some cases more than one value will be available for one wind angle. In such cases a judicious choice of one or combination of the values has to be made, because due to symmetry only one value is possible. We chose an average of the two values for that condition.

Two other parameters effecting Cp are also defined here. They are the roof slope (a) of the wall under consideration and the roof slope (b) of the adjacent wall. These parameters are illustrated in Figure 2-6.

#### NORMALIZED Cp (NCp)

Different researchers have measured Cp based on different heights. Since it has been proposed to use Cp referenced to the velocity at the building height, all Cp data available in the literature referenced with respect to other heights will have to be converted to velocity at building height. For this the velocity profile of the study will have to be known a priori. However this effort can be considerably simplified if the Cp at different wind angles are normalized with respect to Cp at a fixed wind angle. Since Cp at wind angle zero is usually most reliable and this value is provided by most studies, all Cp are normalized with respect to the Cp at the wind angle of zero degrees. This frees all the Cps from the reference height and it is only needed to reference the Cp at zero degrees to the building height. Note that this will result in the value of normalized Cp at zero degrees to be 1 irrespective of all other parameters. Also this facilitates considerable ease in curve fitting.

## 2.2 CONSOLIDATION OF AVAILABLE CP DATA

### INTRODUCTION

In the previous section, the approach to correlating the available Cp data was given. With this in mind an extensive number of available references containing Cp data were surveyed in order to extract the data. The Cp data were closely scrutinized in order to extract useful data for the purposes of data reduction and consolidation. In addition, some researchers in the field were contacted. Many references containing Cp data are presented either in the form of plots with respect to wind angle or as contour plots. In these cases the contour plots were digitized manually and the data were entered into the computer.

### DATA AVAILABLE IN THE REFERENCES

In this section a brief description of each reference reviewed is presented. The actual data extracted (if any) are tabulated as well as presented as plots. The plots also contain the predicted values by equations developed later. For the moment, however, attention is drawn to the values extracted (observed) from the literature only. In each table, the side ratio (S), the roof angle (a) of the wall under consideration, roof angle (b) of the adjacent wall and the actual Cp at wind angle of 0 degrees are indicated followed by the normalized Cp table for the wind angles available. Figure 2-7 shows the shapes of the various models studied by all researchers. Note that none look like typical houses with garages and porches.

#### JENSEN, M and FRANK, N. (1965)

The report describes the results of wind tunnel studies on a number of model houses for both small as well as large turbulence levels. His small and large turbulence levels correspond to open and industrial terrains respectively. Contour plots of Cps for a few different incidence angles are presented. The wind angles are for some selected cases of critical wind angles and loading conditions. Both horizontal and saddle roof type have been included in the building geometry. All pressure coefficients are calculated based on velocity at the highest line in the roof. The results are presented in the form of contour plots. Cps in these plots are given as percentages of velocity pressures at ridge level. Results of studies involving different types of roofs have also been presented for a number of wind angles. Here too, the results are presented in the form of contour plots. The data was extracted by us by carefully constructing a grid over the contour plots and interpolating the values of the contour lines at the mid point of the grids. After interpolating the values, an average for the surface was calculated by averaging the data from the grid points. Tables 2-2 thru 2-5 show the data extracted from this reference along with Figures 2-8 thru 2-11.

CERMAK, J.E., PETERKA, J.A., AYAD, S.S. AND POREH, M (1981)

The report contains the results of wind tunnel studies conducted at Colorado State University (CSU) for a model of the Florida Solar Energy Center's Passive Cooling Laboratory. The dimension of the building modelled was 36x36x24 with a roof slope 1:2. The model scale was 1:25. Configurations with and without surrounding buildings were modelled for a number of incidence angles. (4 wind angles with neighboring building and 8 without). Tabular results of the Cps for all measured point are presented. Only the data without the upwind building was extracted for the purpose of consolidation. Table 2-6 and the Figure 2-12 show the data extracted.

HAMILTON, G.F (1962)

The paper describes the results of wind tunnel studies on cubes, walls and roofed cubes in both constant velocity and boundary layer flows. The roof slopes of the roofed cubes varied from 15 to 45 degrees. For the cube models the wind directions are 0 and 45 degrees while the roofed cubes have wind directions 0,45 and 90 degrees. The exponent for the boundary layer profile is 0.25 and the reference velocity was at the top of the model. All results are shown in the form of contour plots for all the models tested showing the lines of symmetry. Only data from boundary layer flow was extracted in a manner similar to the procedure adopted for data from JENSEN. Tables 2-7 thru 2-10 with the appropriate Figures 2-13 thru 2-16 show the data extracted for consolidation.

VICKERY, B.J., BADDOUR, R.E., KARAKATSANIS, C.A. (1983)

The report presents the results of a comprehensive set of wind tunnel tests for low rise buildings in both open as well as suburban terrains. The building modelled has plan dimensions of 80x125. Three different heights (16,24 and 32 ft) and three different roof slopes (1:12,4:12 and 12:12) have been modelled for wind angles 0,45 and 90 degrees. Additionally, a 80x100x16 house has been modelled in open terrain for wind angle between 0 and 90 in steps of 10 degrees. The reference speed is taken at eaves height and the Cp values are presented in the form of tables. Cp data is reported at 18 points for the long walls and at 9 points for the short walls. However, since only mean Cps is of interest for calculation of ventilation rates, we have averaged the data over each surface.

Tables 2-11 to 2-15 and the Figures 2-17 thru 2-21 show the data extracted from this reference.

WIREN, B.G (1985)

The report describes the wind tunnel study of a 1:100 scale model 1-1/2 storey single family houses typically found in Sweden. The house considered has a dimension of 85:100:32 with a roof slope of 1:1. The experiments were carried out for open profile

(exponent=0.14). The thrust of the work reported was to generate sufficient data for infiltration calculation for the Swedish houses with different patterns of neighboring buildings. Cp data for different experiments are available in the form of plots as well as data on tape. Cps are referenced with respect to roof height. Then the air change rates calculated using mean surface Cps are compared with the rates calculated using eighty local Cps values in this report and the maximum error never exceeded 20%. A similar calculation performed by us using data from Vickery showed that the maximum error involved fell in the same range. Table 2-16 and the Figure 2-22 show the data extracted from WIREN (1985) for the unobstructed building only. The data on the sheltering are dealt with separately in Section 2.4.

AKINS, R.E., and CERMAK, J.E. (1976)

The report describes the methodology and results of a comprehensive set of wind tunnel tests of a series of flat-roofed rectangular building models in four different boundary layers. The exponent for the profile are 0.12, 0.26, 0.34 and 0.38. Side ratios simulated were 1.0, 0.5 and 0.25. Incidence angles considered are 0, 20, 40, 70 and 90 degrees. The pressure coefficients are referenced with respect to the local velocity at the point of measurement making them independent of height and boundary layer profile. The buildings modelled fall in the category of medium to tall buildings.

Results of mean Cps averaged over aspect ratios and boundary layers were available in tabular form for three aspect ratios and four wind angles for all the surfaces of the building. Removing terrain and aspect ratio dependence has considerably simplified the data. Data for analysis for tall buildings have been exclusively taken from this reference. Because of the volume of data involved, this has been dealt with separately in Section 2.6 under tall buildings and are not presented in this section.

G. LUSCH, G., and TRUCKENBRODT, E. (1964)

Four buildings of different heights have been extensively tested and the results presented in this reference. The roof angles for each have been varied from 0 to 60 degrees in steps of 10 degrees. Although four building heights have been investigated, only the data for the low rise building (where height is half of width) has been extracted by digitizing the appropriate curves. The data extracted by us from this reference is shown in Table 2-17 thru 2-22 and the Figures 2-23 thru 2-38.

ASHLEY, S.K (1984)

The report presents the results of wind tunnel as well as field tests on three Navy buildings of side ratios 0.125, 0.3 and 0.36 at six different wind angles. All buildings have sloped roofs along the longer walls. The Cps have been referenced with the velocity at the roof level. The velocity profile used in the wind tunnel tests were closer to suburban profile having an

exponent of 0.20. Tables 2-23 thru 2-25 and the Figures 3-29 thru 3-31 show the data extracted by us from this reference.

In addition, data from AKINS for three other buildings of three stories or less have also been presented in this reference. The data were also extracted by us and are shown in Tables 2-26 thru 2-28 and in the accompanying Figures 2-32 thru 2-34.

TIELEMAN, H., AKINS, R.E and P.R. SPACKS (1980)

This paper compares  $C_p$  values between full-scale and model-scale buildings and discusses discrepancies between the two where they occur. Both, the Aylesbury house as well as the Price Fork house have to be considered for this purpose. The Aylesbury house is modelled at University of Western Ontario (UWO) (Scale 1:500 in BLWT) and at Virginia Polytechnique Institute and State University (VPI&SU) (Scale 1:24, Walls only). Their results show good comparison for the  $C_p$ s of the windward walls. Wind tunnel data for the windward walls are shown from 0 to 360 degrees and compared to full-scale in the direction of available wind in the field. Neither detailed geometric data of the building nor the characteristic of the terrain simulated is available in the paper.

Since, the primary purpose in the paper has been to validate wind tunnel data with field data only for the wind angles available in the field, no data could be extracted from here.

VICKERY, P.J AND SURRY, D. (1983a)

The paper compares the  $C_p$  values obtained from full-scale and wind tunnel studies for the Aylesbury house. A 1:100 scale model was tested for a single roof pitch and wind angle and eight boundary layer (B.L) profiles. The reference speed chosen was the velocity at 10m (full scale). Mean, rms and peak pressure coefficients are calculated. Eight different wind simulations are done starting from the worst possible case where the B.L was not correctly scaled to the best where correct B.L was modelled. The observation of the paper suggests that the mean  $C_p$  will be in agreement with full scale data if the mean velocity profile is reproduced accurately over the building height. For the eight B.L simulated, the maximum variation between any two simulations was 25% for the measured mean  $C_p$ .

Since the primary aim of the paper is to compare full-scale and model-scale results, the comparison is made only for wind angles available in the field. Although all four walls and two roof sides have been included in the comparison, the results are of little use in our consolidation.

HOLDO, A.E., HOUGHTON, E.L and BHINDER, F.S. (1982)

The paper assesses the effect of variation of the ratio of longitudinal turbulence integral length scale to the body dimension ( $L_x/D$ ). Firstly a comparison of  $C_p$ s with uniform flow

and turbulence flow are made for the long and short walls as well as the roof.  $C_p$  data for uniform flow and turbulent flow are plotted for wind angles between 0 and 180 degrees. Secondly, comparison of wind tunnel data with full scale measurements are made. The results indicate that the best comparisons are when the  $L_x/D$  ratios are closest.

The paper deals with the considerations involved in simulating field condition in wind tunnels to obtain close comparison of data. Some data with wind angle variations are available in the paper which have to be read visually from the plots. No specific data of the building geometry or of the terrain simulated is available in the paper.

BOWEN, A.J (1976)

The paper gives data on comprehensive tests on  $C_p$  measurements for tall buildings in a typically high density urban boundary layer. The models represent a plan of 100x150 ft with heights between 50 to 300 ft with flat roof which is typical in most tall buildings. Wind angles simulated in this study are 0,5,10,15,30,45,60,75,80,85 and 90 degrees. A further angle of 135 degrees was also used to cross check accuracy. The coefficient of pressures are calculated with respect to the velocity at the top of the building height and averaged using weighting factors depending on the area of influence of the point being measured. The paper contains detailed measured data of  $C_p$ s for each building type for all four surfaces and roof for various wind angles. This data was not considered as the Akins data set for tall buildings (see Section 2.6) is comprehensive and covers the cases studied here.

LEE, B.E., HUSSIAN, M., SOLIMAN, B. (1979)

The report presents both theoretical as well as experimental approach to assessment of wind induced natural ventilation in buildings. A suburban terrain atmosphere boundary layer was utilized having an exponent of 0.28. Three phases of the tests carried out were to study (1) the effects of array patterns on cubic models, (2) the effect of frontal aspect ratio and (3) the effect of side ratio. The first phase was carried out for wind angles between 0 and 90 degrees while phases 2 and 3 are for wind angle 0 only. In each phase different density patterns of neighboring buildings were studied. All  $C_p$  data reported are with respect to velocity at gradient height. An interesting result is presented in this report. The  $C_p$  difference normalized with respect to the  $C_p$  difference at zero degree wind angle is plotted against wind angle. The result shows that regardless of the density pattern all the data approximately fall on to a single curve. This produces considerable simplification in using the data.

However, all results in the report are presented in the form of  $C_p$  differences across opposite walls and will be useful only for specific window locations. The data, therefore, is in a form

unsuitable for our purpose and approach. Moreover similar or better data is available in Wiren (1985) which we have used.

KELNHOFER, W.J (1977)

The paper presents some results of wind tunnel experiments including the effects of a single neighboring building. The model selected is a tall building with height four times the width. Both uniform as well as shear flow have been simulated. However no data on the B.L. profile has been presented and the terrain is, therefore, not known. Cps have been calculated based on free stream velocities.

Although it appears that a large number of data were generated in the experiments, both the amount and form of data presented in the paper makes it unsuitable for use in data consolidation.



### 2.3 DATA REDUCTION FOR LOW RISE BUILDINGS

In the previous section,  $C_p$  data was extracted from a number of sources and was presented in a normalized form. The need for the normalized form as well as the assumptions and simplifications used were discussed in Section 2.1. In this section, the approach taken to curve fit the assimilated  $C_p$  data is given followed by the curve fit equations. There are 544 data points which need to be fit. These 544 wall average data points represent several thousand local  $C_p$  data which were digitized from contour plots.

#### APPROACH TO CURVE FITTING

The computer program, SPSS-X (1986) was used for the purpose of obtaining curve fit for the normalized  $C_p$  data. A large number of possible parameters created from the combination of wind angle, side ratio and roof angles were supplied as input to SPSS-X and a large number of curve fits were generated. These outputs were then studied to see which of the input parameters effected the value of  $C_p$  appreciably. Based on these results more parameters were created and insignificant parameters deleted and the program was executed again. By this process, the number of significant parameters were narrowed down to a manageable level. During one such run it was noticed that the exponentiation of the dependent variable (normalized  $C_p$ ) produced higher correlation coefficients (up to 0.81) compared to the correlation coefficients obtained (up to 0.76) by fitting the normalized  $C_p$  without exponentiation. All subsequent runs were, therefore, made with the transformed dependent variable.

#### SIGNIFICANT PARAMETERS

SPSS-X was run with a large numbers of possible parameters which were thought to affect  $C_p$ . The parameters found to influence  $C_p$  as obtained from the runs are discussed below:

##### WIND ANGLE

With the dependent variable (normalized  $C_p$ ) transformed by exponentiation, functions of wind angle turned out to be the most significant parameters. SINE and COSINE functions of the wind angle showed high correlation coefficients.

##### SIDE RATIO

The next important parameter influencing  $C_p$  is the side ratio ( $S$ ). The side ratio could be either greater than 1 or less than 1 depending on the wall under consideration. Since it was noticed that the normalized  $C_p$  value is less for  $S$  less than 1 and greater for  $S$  greater than 1, it was hypothesized that the natural logarithm of the side ratio would be an appropriate parameter affecting  $C_p$ . This is because the natural logarithm of  $S$  would be negative when  $S$  is less than one; and positive for  $S$  greater than one. The runs made with SPSS-X showed that this was

indeed so. The side ratio parameters were therefore primarily chosen in terms of its natural logarithm.

#### ROOF ANGLES

The roof angles a and b as described in Section 2.1, were normalized by dividing them by 180. The largest roof angle available in the data was 60 degrees. Roof angles are least significant of the parameters. In fact, the roof angle b, did not show any significant effect in the fit.

#### EQUATION FOR NORMALIZED $C_p$

With the significant parameters obtained, the actual form was chosen observing the following constraints due to the nature of the data. The following are the constraints.

1. Irrespective of all other parameters the normalized  $C_p$  must always be equal to 1 for zero degrees wind angle.
2. The terms containing the roof angles in the equation must disappear from the equation when they are zero leaving the rest of the equation intact.
3. Since the natural logarithm of the side ratio has been taken to be the significant parameter, these terms will become zero for  $S=1$ . These terms must be so chosen that it does not effect the other terms of the equation during this case. In order to abide by these constraints, terms containing side ratio as well as the roof angles were combined with SINE functions of wind angle so that these terms would vanish for wind angle of zero degrees.

The results from two final runs are shown in Tables 2-29 and 2-30. The first table shows the results of the final run with the roof angle parameters included and the second is without. Given a set of variables, SPSS-X automatically selects the most significant one first and gives the coefficients automatically. Thus in Table 2-29, the first column indicates the order in which SPSS-X ranked the most important variables.  $\sin(AS/2)$  was more important than  $\sin^2(AS)$  and so on. Note that due to the nature of the data,  $\sin(AS)$  did not get picked up even though it was specified as an input variable. Both tables show the value of the  $R^2$  and the coefficients obtained when the parameters listed were selected automatically one after another in order of their significance. The first column of each table are the values of the actual correlation coefficient calculated based on the values of predicted and observed normalized  $C_p$ s. This is different from the correlation coefficients obtained in the SPSS-X runs, because SPSS-X gave the correlation coefficients for the fit of the transformed dependent variable ( $\text{EXP}(NC_p)$ ). The second row of each table shows the percent change in the value of the correlation coefficient when a parameter was included in the fit. It is apparent from the first table that the least percent

change (0.127%) in the correlation coefficient is observed when the roof angle  $\alpha$  was included into the fit. It became clear not only that the roof angle is the least significant parameter that affects the value of  $NCp$ , but also that the experimental data presently available in the data base is insufficient to justify its inclusion as a parameter of significance. Further, the data shows erratic variations for  $NCp$  with respect to the roof angles and no firm trend is visible. Because of these uncertainties it was felt best at this time to drop the roof angles  $\alpha$  and  $\beta$  from the curve fit.

Consequent to the above discussion, a final run without inclusion of the roof angles was made. The result of this is shown in Table 2-30. The largest correlation coefficient obtained was 0.811 with inclusion of nine terms in the equation. The percentage change in the correlation coefficients decreases steadily with the inclusion of each term. It can be seen from the table that after the sixth term the percent change in the correlation coefficient is only marginal. Figures 2-35 thru 2-43 show the scatter plots of the predicted versus observed values with the inclusion of one term after another. Note from the figures that only marginal benefit is obtained after the sixth terms.

The cut off limit for the inclusion of terms was decided based on the change in the correlation coefficient with its inclusion. All terms which produced a change less than one percent were ignored and the final equation for normalized  $Cp$  ( $NCp$ ) was based on larger significant terms are as follows:

$$EXP(NCp) = C_0 + C_1 \cdot \sin(\alpha/2) + C_2 \cdot \sin^2(\alpha) + C_3 \cdot \sin^3(2 \cdot \alpha \cdot G) + C_4 \cdot \cos(\alpha/2) + C_5 \cdot G^2 \cdot \sin^2(\alpha/2) + C_6 \cdot \cos^2(\alpha/2) \quad \dots \text{Eq 2.1}$$

Where:

EXP denotes exponentiation.

$$\begin{aligned} C_0 &= 1.248 \\ C_1 &= -0.703 \\ C_2 &= -1.175 \\ C_3 &= 0.131 \\ C_4 &= 0.769 \\ C_5 &= 0.071 \\ C_6 &= 0.717 \end{aligned}$$

and

$$\begin{aligned} \alpha &= \text{wind angle} \\ G &= \ln(S) \text{ (Natural log of side ratio)} \end{aligned}$$

The correlation coefficient for the above equation is 0.797 which is a good value considering the diversity of the data.

The above equation was used to plot the predicted value of  $NC_p$  over the observed values in Figures 2-8 thru 2-34. Note that the curve fit performs adequately for most of the experimental data.

#### Cp AT ZERO INCIDENCE

Table 2-31 gives  $C_p$  values for zero incidence. Figure 2-44 shows the data in a histogram form. The values presented in the table and figure are the values extracted from the references surveyed and converted with respect to the velocity at the model height. This was done using the boundary layer profile characteristics extracted from the references. Looking at the data it becomes obvious that they are highly diverse showing no firm trend with respect to any parameter whatsoever. While it is expected that the open terrain should have higher  $C_p$ s than the suburban terrain which is the case with Vickery's data, cross comparison of Vickery's open terrain data with suburban data of other references such as Ashley, shows just the opposite. Jensen's values for large turbulence are always higher than for small turbulence clearly indicating a conflict in the data trend. Akins on the other hand shows no change between short and longwall for all three aspect ratios. One can only infer that a proper analysis of  $C_p$  at zero incidence is possible only when data with all parametric variations is done using a single experimental setup and that an attempt to correlate such diverse set of data would prove futile due to inherent characteristics of the experiment of each researcher. It should be pointed out that the idea of normalized  $C_p$  analysed earlier removes many of the uncertainties of individual experiments from which data is gathered.

In light of the above it is suggested that a uniform value of 0.60 be chosen to represent  $C_p$  at zero incidence for all types of low rise buildings. This represents the average of all  $C_p$ s at zero incidence.

## 2.4 SURROUNDING EFFECTS AND DISCHARGE COEFFICIENTS

Surrounding buildings and building patterns effect the magnitude as well as distribution of  $C_p$  on a building surface and can considerably change natural ventilation rates. The study of their influence is therefore necessary if ventilation rates have to be calculated with a certain degree of accuracy. This section analyses the effect of a single neighboring building as well as the effect of neighboring building patterns. Effect of garages, wingwalls and U-shaped construction are also discussed.

### APPROACH

Data for this analysis have been exclusively taken from WIREN (1985). The layout of the experiment performed by WIREN are shown in Figures 2-45. Figure 2-45a shows a rectangular pattern arrangement most commonly found in residential communities. Data was available from WIREN for this pattern for the spacing ratios shown in figure of 1, 1.5 and 2. Figure 2-45b shows a pattern in the shape of concentric hexagonal around the experimental building. Data for this pattern is also available for spacing ratios of 1, 1.5 and 2. Figure 2-45c shows the layout for studying the effect of a single neighboring building performed by Wiren (1985).

The approach used by us in analyzing the effect of surrounding building was to study the effect of the change in  $C_p$  due to the obstruction. In all cases,  $C_p$  data from WIREN was reformatted according to our conventions described in Section 2.1. Details of the data analysis is given below. The difference in  $C_p$  was taken as the parameter for analysis rather than some form of normalization in order to avoid division by zero or very small values which may arise at certain wind angles.

### $C_p$ REDUCTION IN RECTANGULAR PATTERN

Figure 2-46 shows the difference in  $C_p$  between the building in the rectangular pattern and unobstructed pattern for all the arrangements in the rectangular pattern (D11,D12,D13,F11,F12,F13,H11,H12,H13) with respect to the wind direction. The difference due to each of the configurations are not much different and it would be reasonable to assume an average difference for all arrangements in this pattern. Figure 2-47 shows the average difference in this category with respect to wind angle. The differences were curve fitted using the computer program DATAPLOT (1977). The equation used and the coefficients used are given below. WIREN has used the velocity at the roof top (74 mm) as the reference. The conversion factor to properly reference the  $C_p$ s to the velocity at the eave height (32 mm in Wiren's model) is 1.26 (given by  $(74/32)**0.28 = 1.26$ , where 0.28 represents twice the exponent of the velocity profile used in Wiren's model).

$$AD = 1.26*(A0 + A1*AN + A2*AN^2 + A3*AN^3 + A4*AN^4) \dots \text{Eq 2.2}$$

Where AD : is the change in Cp due to this surrounding pattern  
 AN : Wind angle/180.00 (= AS/180)

A0 = -0.309  
 A1 = -1.061  
 A2 = 12.304  
 A3 = -20.490  
 A4 = 9.766

Figure 2-48 is a plot of the calculated versus the actual difference in Cp for this arrangement without modification for reference height.

#### Cp REDUCTION IN HEXAGONAL PATTERN

Figure 2-49 shows the difference in Cp between the building in the rectangular pattern and unobstructed pattern for all the arrangements in the rectangular pattern (E11,E12,E13,G11,G12,G13,I11,I12,I13) with respect to the wind direction. Here again, the difference due to each of the configuration are not much different and it would be reasonable to assume an average difference for all arrangements in this pattern. Figure 2-50 shows the average difference in this category with respect to wind angle. The Cp difference was curve fitted using DATAPLOT. The equation used and the coefficients used are given below. As previously explained earlier for rectangular patterns, a factor of 1.26 should be applied to the equation in order to properly reference the Cps to eave height.

$$AD = 1.26*(A0 + A1*AN + A2*AN^2 + A3*AN^3 + A4*AN^4) \dots \text{Eq 2.3}$$

Where AD : is the change in Cp due to this surrounding pattern  
 AN : Wind angle/180.00 (= AS/180)

A0 = -0.230  
 A1 = -1.004  
 A2 = 9.253  
 A3 = -14.119  
 A4 = 6.240

Figure 2-51 is a plot of the calculated versus the actual difference in Cp for this arrangement without modification for reference height.

#### EFFECT OF A SINGLE BUILDING

The effect of a single neighboring building was analysed from the data of configurations A10,A20,A30,A40 from WIREN (See Fig 2-45c). After the data was reformatted, a convention for the location of the neighboring building was developed. Another angle called the obstruction angle, AW, is defined which is the angle between the wind direction and the line joining the centers of the two buildings. Figure 2-45d illustrates the convention

for this angle. Again the change in  $C_p$  from the unobstructed case was calculated in order to relate them to other parameters.

Figure 2-52 thru 2-58 shows the plots of the change in  $C_p$  for each of the four arrangements (A10,A20,A30,A40) against wind angle for each obstruction angle, AW, available in the data. Some interesting observations can be made from these plots. Firstly, the change in  $C_p$  is dependent on the spacing of the neighboring building as well as the wind angle. The difference decreases rapidly with AW and the effect of the neighboring building virtually disappears above AW greater than 45 degrees. It may be safely assumed that any neighboring building situated such that AW is greater than 45 degrees will have no effect. The effect also decreases as the neighboring building is moved further away. The following equation fits the data satisfactorily and can be used to determine the  $C_p$  reduction due to a single building.

$$AD = 1.26 * \text{EXP}(-3 * AR) * \{A1 * \text{SIN}(AS - 47.0) / SF + A2 * [\text{SIN}(AS - 47.0) / SF]^2 + A3 * [\text{SIN}(AS - 47.0) / SF]^3\} \quad \dots \text{Eq 2.4}$$

Where AD : is the  $C_p$  difference  
 AR :  $AW * 3.1415 / 180.0$  (obstruction angle in radians)  
 SF : spacing factor (see definition section 1.3)  
 AS : wind angle (in degrees)

The coefficient of the equation are:

$$\begin{aligned} A1 &= 1.039 \\ A2 &= -0.0476 \\ A3 &= -0.684 \end{aligned}$$

Note : If obstruction angle AW is more than 45°, AD may be taken to be zero without invoking the above equation .

#### OTHER SURROUNDING EFFECTS

The above cases of surrounding effect do not encompass all possible cases which occur in actuality. For those cases, factors for calculating reduction in airflow due to shielding were calculated based on the generalized shielding coefficients of SHERMAN and GRIMSRUD [1982]. The equation for the wind induced infiltration for evenly distributed leakage area as given by them is :

$$Q_w = V_o \sum_j L_j C_j'$$

Where

$Q_w$  is the flow  
 $L_j$  is the leakage area of the  $j$ th site  
 $C_j'$  is the generalized shielding coefficient.  
 $V_o$  is the wind speed.

Any change in flow due to surrounding is effected by a change in the value of the shielding coefficient C' which is given for five shielding classes. Taking the Shielding Class I of Sherman and Gimsrud to represent a totally unobstructed house, we calculated the correction factor to be applied for the other classes by taking the ratio of the Sherman and Gimsrud's coefficients with respect to the unshielded class. The correction factors calculated are give below.

Shielding Class	Correction Factor (SCF)	Description
I	1.0	No obstruction or local shielding whatsoever.
II	0.88	Light local shielding with few obstructions (e.g. a few trees or a shed in the vicinity).
III	0.74	Moderate local shielding; some obstructions within two house heights ( e.g. thick hedge or fence and nearby buildings).
IV	0.57	Heavy shielding; obstruction around most of perimeter building or trees within five building heights in most directions (e.g. well developed dense tract houses)
V	0.31	Very heavy shielding, large obstruction surrounding perimeter within two house heights (e.g. typical downtown area).

Note that these correction factors should be used only if no other corrections have been made for surrounding effects and is to be applied to the ventilation flow rate and not Cps.

$$\text{Corrected ACH} = \text{ACH} * \text{SCF}$$

#### PRESENCE OF GARAGE OR WING WALLS

The presence of a garage wall or wingwall protruding from a wall will drastically effect the value of Cp depending on the approach wind angle. Figure 2-59 shows a typical layout. No measurement data is available for this case of practical importance. the following is our best engineering judgement. Studies done by Chandra et. al. (1983) show that up to an angle of 90 degrees between the garage wall and the approach wind towards in the positive direction as shown in the figure, the value of Cp on the wall may be assumed to be the value at zero incidence. For angles in the positive direction beyond the effect of the garage or wing wall is minimal and therefore no modification is



suggested. For angles in the negative direction as shown in Figure 2-59, the presence of the garage or wingwall produces suction velocities causing negative pressures as if the wind is approaching from the leeward side. In this case it is suggested that the window areas of the wall may be added to the window area(s) of leeward wall of the building.

#### U-SHAPED BUILDING

Figure 2-60 shows a typical U-Shaped building. As for garages, measured data is unavailable for this common building shape. Again common sense guidelines are recommended. The  $C_p$ s of the wall forming the inner surfaces of the U should be modified as follows. For approach wind up to 45 degrees on both sides of line OO (Fig 2-60) the  $C_p$  values of all the U- walls may be taken as the value at zero incidence because for this case positive pressures will be experienced by those walls. For angles beyond 45 degrees up to 60 degrees on both sides of line OO, the wall facing away from the wind approach is likely to be experiencing suction conditions, while the other two walls are likely to be experiencing positive pressures. The wall facing away from the wind direction should be treated as if it were leeward wall and its area should be added to the leeward wall of the building. The  $C_p$  for the other two walls of the U may be taken as  $C_p$  at zero incidence. For angles beyond 60 degrees, the flow is likely to bypass the U region, and all walls of the U will experience suction. Therefore the areas of windows on these walls should be added to the window areas of the appropriate leeward wall. Figure 2-60 illustrates the different cases.

#### DISCHARGE COEFFICIENTS

Literature data on discharge coefficients,  $C_d$ , for orifices in pipe flow has been presented by Vickery (1983). These data for inlet and outlet conditions for high Reynolds numbers are reproduced in Figures 2-61 and 2-62.

In typical natural ventilation situations the largest aperture dimension one is likely to encounter is a sliding glass door. Even a 4 ft x 7 ft opening is typically only 3%-5% and at most 10% of the wall dimension. Thus, for a large majority of apertures the appropriate value of the parameter  $A_o/A$  used in Figures 2-61 and 2-62 will be  $<0.1$ . In this range the value of  $C_d$  does not change very rapidly and based on the data in the figures a  $C_d$  value of 0.62 is recommended for all calculations.

It is to be noted that the use of different  $C_d$  equations for inlets and outlets per Figures 2-61 and 2-62 is quite cumbersome in practice, because one does not know a priori, which windows will be inlets and which outlets.

## 2.5 MINIMUM VENTILATION AND SINGLE WINDOWS

### MINIMUM VENTILATION RATES

Anemometers have a typical threshold of about 0.5 mph. Under these so-called "calm" conditions the windspeed may be reported as zero in the weather tapes.

However, in practice that is not the case. At FSEC, we, over the years, have conducted many ventilation air change measurements with the SF6 tracer gas decay technique. We have routinely found that rooms and houses with open windows have a minimum measured air change rate of between 2.5 and 4 ach, even under calm conditions and less than 50F temperature difference between indoor and outdoors.

For this reason we recommend 3 ach as the minimum ventilation rate for calculation purposes even if the calculation procedure predicts a smaller ventilation rate. The different ventilation measurements which were conducted are briefly summarized below.

#### Bettencourt House (1981)

The Bettencourt house located in Eustis, Florida is a small 878 sq ft house with open window area totaling 12.3% of floor area. In 1981, ventilation rates were measured 16 times. The two lowest measured values were 4.1 ach and 4.2 ach at measured site 10 m windspeeds of 0.4 mph and 0.8 mph respectively.

#### FSEC Passive Cooling Lab (PCL), 1984

Measurements were made in a FSEC PCL room. The room dimensions were 18' x 11' x 8' and it had apertures on ceiling (coupled to one attic) and a window totaling 8.9 sq ft or about 4.5% of the floor area. 3.8 ach was measured at a site 10 meter windspeed of 0.5 mph.

#### Rangewood Villas, 1986

SF6 tracer gas testing was performed on August 14, 1986 from 9 P.M. to 10 P.M. under conditions of nearly calm winds. Windows open totaled 57.5 sq ft in a two story townhouse with 1200 sq ft. The air change ratio was 2.65 ach with a measured site windspeed of 0.0 mph.

### VENTILATION THROUGH SINGLE WINDOWS

If a room has only one open window and the internal door is closed, there will not be any ventilation due to pressure differences but ventilation will still be present due to turbulent diffusion. We have located three studies dealing with this type of ventilation. All three propose algorithms where the ventilation rate is proportional to the product of the open window area and the wind speed. BRE Digest 210 (Anon., 1978) recommends

$$Q = 0.025 A V \quad \dots \text{Eq 2.5.1}$$

where Q is the flow rate in m<sup>3</sup>/sec, A is the open aperture area in sq.m and V is the reference wind speed at the site at building eave height. Warren (1978) recommends a formula

$$Q = 0.02 A V \quad \dots \text{Eq 2.5.2}$$

which is obviously very close to Eq 2.5.1. Warren notes that this formula is overly conservative in that measured Q can be considerably higher. Cockroft and Robinson (1976) present measured data for a 48 m<sup>3</sup> room as follows:

A sq.m	V (m/s)	Q (cu.m/s)	ACH
0.2	2.5	0.0183	0.51
	5.5	0.0717	1.99
	7.5	0.0137	3.8

This data shows Q to be a non linear function of the AV product. All authors note that further complications will arise if awning or casement windows are used, as they will tend to catch the air which is generally moving in the plane of the wall.

Needless to say, the ventilation provided by one open window is minimal, and is generally not adequate for summertime ventilative cooling. Therefore, this case should not be of particular interest to designers. Researchers can probably use an equation like

$$Q = 0.05 A V \quad \dots \text{Eq 2.5.3}$$

to get an estimate of natural ventilation for this case.

## 2.6 DATA REDUCTION FOR TALL BUILDINGS

The analysis and approach to fitting the  $C_p$  data for tall building is discussed in this section.

### APPROACH TO CURVE FITTING

The quantum and nature of data available for tall buildings is different from that available for low-rise building. As mentioned in Section 2.2, data for analysis in this category have been exclusively taken from Akins (1976). Data from Akins is available for all four surfaces for three buildings (length to width ratios 1, 2 and 4) and for 5 wind angles. Further, for each wall,  $C_p$  data is available for 110 locations on the surface. Thus over 5000 data points were hand entered into the computer and is not repeated here. The volume of data is therefore considerable and is not presented in this report. The horizontal and vertical coordinates (XL and ZH) of the points on the wall are nondimensionalized with respect to the length and height of the wall. The  $C_p$ s are referenced with respect to the velocity at the height of measurement.

Because Akins (in using local  $C_p$ s) found no dependence on either terrain or height of the building, no attempt was made by us to normalize the  $C_p$  data and we decided to curve fit the actual  $C_p$  data. However, the data was converted according to out conventions of wind angle (AS) and side ratio (S) in order to eliminate the wall surface number as one of the variables. The nondimensionalized horizontal and vertical locations, however, require closer scrutiny. It appears from Akins' that the origin of the coordinates seems to be the lower left hand corner of the wall when viewed from outside. If these two coordinates are to be used as dependent parameters to fit the  $C_p$  data a problem arises. Figure 2-63a illustrates the convention used by Akins. Note that according to this convention, for an approach angle of zero degrees (Fig 2-63a for a square building) the  $C_p$  at the location 0 of wall 1 will be equal to the  $C_p$  at location 1.0 of wall 3. Similarly at an approach angle of 90 degrees the location 0 on wall 2 will be equal to the  $C_p$  at location 1.0 on wall 4. The problem was simply resolved by redefining the origin for each wall as the lower corner closer to the tail of the approach wind. That is, the origin should be always directed away from the prevailing wind direction. Figure 2-63b shows this redefinition. The redefined coordinates are labeled as XL and ZH. (Note that ZH did not require any redefinition as no problem arose with it). The data then converted using this convention, gave us  $C_p$  as a function of wind angle (AS), side ratio (S) and the coordinate location on the wall (XL and ZH). Analysis was carried out using SPSS-X.

### SIGNIFICANT PARAMETERS

Analysis of Akins data posed some difficulty in arriving at the functional form to be used for the different parameters especially for the side ratio (S). The data was therefore split

into five categories based on side ratios of 1.0, 2.0, 4.0, 0.25 and 0.5. With the side ratio eliminated as a parameter, these five data sets were independently analysed for the other parameters namely wind angle and surface locations (XL and ZH). A large number of runs were carried out to get similar variables to fit all the five data sets and five equations differing only the values of the regression coefficients were obtained. Table 2-32 shows the regression coefficients and correlation coefficients obtained by analyzing the five data sets. The correlation coefficients varied from 0.88 to 0.92.

Once the regression coefficients were obtained for each of the five sets of data, the regression coefficients were themselves analysed for dependence on the side ratio (S). Corresponding regression coefficients for each term of the five data sets were fit into the form

$$C_n = a + b*S^c$$

where  $C_n$  are the coefficients of a particular term for all the data sets, and

$a, b, c$  are regression coefficients which curve fit the original coefficients obtained from the five sets of data.

Once the functional form of the side ratio was obtained, new parameters were developed from the combination of AS, XL, ZH and S, reflecting these functional forms and the new parameters were used as input to curve fit the entire data of Akins.

Table 2-33 shows the results of the analysis performed on all the data of Akins. The largest correlation coefficient obtained was 0.89. Figure 2-64 shows the scatterplot for all of Akins data. The final equation obtained for  $C_p$  for tall buildings is:

$$\begin{aligned} C_p = & C_0 + C_1*Ar + C_2*\cos(2*AS) + C_3*ZH*\sin(AS)*S^{0.169} + \\ & C_4*\cos(A*AS)*S^{0.279} + C_5*\sin(2*AS) + C_6*ZH*\cos(AS) + \\ & C_7*\cos(Xr) + C_8*\cos(Xr*AS) + C_9*\cos(Xr*AS)*S^{0.245} + \\ & C_{10}*ZH*\sin(AS) + C_{11}*Xr*\sin(AS) + C_{12}*XL + \\ & C_{13}*\cos(Xr)*S^{0.85} \end{aligned} \quad \dots \text{Eq 2.6}$$

Where

$$Ar = AS*3.1415/180 \text{ (wind angle in radians)}$$

$$Xr = (XL-0.5)/0.5$$

and

AS, S, XL and ZH have their usual meaning  
(See definition in Section 1.3)

The coefficients of the equation are:

$C_0 = 0.068$	$C_1 = -0.839$
$C_2 = 1.733$	$C_3 = -1.556$
$C_4 = -0.922$	$C_5 = 0.344$

C6 = -0.801  
C8 = -0.961  
C10 = 2.515  
C12 = -0.431

C7 = 1.118  
C9 = 0.691  
C11 = 0.399  
C13 = 0.046

## 2.7 COMPARISON OF PREDICTED AND MEASURED VENTILATION RATES

Sample calculations comparing predicted and measured ventilation rates are presented in this section. Comparison is done against measured data from Chandra (1983). Chandra (1983) provides ventilation rates measured in the FSEC PV house for three different wind directions. Figure 2-65 is a plan of the FSEC PV house showing the window locations and their areas. The window areas are open aperture areas with insect screening. Also shown below the figure are the wind directions, wind speed and the measured ventilation rates. The volume of the PV house is 9300 cu. ft.

The ventilation rates for the three angles are calculated below using the procedures outlined in Part 1 of this report. In all cases, the terrain type II was assumed. i.e a terrain constants  $a=1.0$  and  $b=0.15$  were used. A discharge coefficient of 0.62 was also assumed.

## WIND DIRECTION 87 DEGREES

WINDOWS -->	SOUTH	EAST	NORTH	WEST
Wind angle (deg)	93	177	87	42
Side ratio	1.56	0.64	1.56	0.64
Window area (sq. ft)	16.91	10.67	15.3	2.66
Cp (form Eq 2.1)	-0.337	-0.337	-0.253	0.347

Note: Correction for presence of garage is applicable to the north wall and  $C_p=0.6$  must be used for that wall as per Section 1.5.

From Eq 1.4.1a, the reference velocity at eaves height is given by

$$V_{ref} = 5.6 * 88.0 * (7.66/33.2) ** 0.15 = 396 \text{ fpm}$$

Using the above values, the calculation procedure C of part 1 yielded ACH = 22.56

Applying, the Sherman and Grimsrud correction for shielding for class II (correction factor=0.85 from Section 1.6), as well as correction factor (=0.85) for insect screening from step 6 of calculation procedure, the corrected air change is:

$$\begin{aligned} \text{ACH} &= 22.56 * 0.88 * 0.85 = 16.9 \\ \text{ACH measured} &= 19.0 \text{ (Chandra, 1983)} \\ \% \text{ difference} &= -11\% \end{aligned}$$

## WIND DIRECTION 140 DEGREES

WINDOW-->	SOUTH	EAST	NORTH	WEST
Wind angle (deg)	40	130	140	50
Side ratio	1.56	0.64	1.56	0.64
Window area (sq. ft)	16.91	10.67	15.3	2.66
Cp (form Eq 2.1)	0.387	-0.742	-0.376	0.245

From Eq 1.4.1a, the reference velocity at eaves height is given by

$$V_{\text{ref}} = 9.7 * 88.0 * (7.66/33.2)^{0.15} = 686 \text{ fpm}$$

Using the above values, the calculation procedure C of part 1 yielded ACH = 39.99

Applying, the Sherman and Grimsrud correction for shielding for class II (correction factor=0.85 from Section 1.6), as well as correction factor (=0.85) for insect screening from step 6 of calculation procedure, the corrected air change is:

$$\begin{aligned} \text{ACH} &= 39.99 * 0.88 * 0.85 = 29.9 \\ \text{ACH measured} &= 29.8 \text{ (Chandra, 1983)} \\ \% \text{ difference} &= 0.4\% \end{aligned}$$

WIND DIRECTION 152 DEGREES

WINDOW-->	SOUTH	EAST	NORTH	WEST
Wind angle (deg)	28	118	152	62
Side ratio	1.56	0.64	1.56	0.64
Window area (sq. ft)	16.91	10.67	15.3	2.66
Cp (form Eq 2.1)	0.487	-0.943	-0.312	0.049

From Eq 1.4.1a, the reference velocity at eaves height is given by

$$V_{\text{ref}} = 7.1 * 88.0 * (7.66/33.2)^{0.15} = 502 \text{ fpm}$$

Using the above values, the calculation procedure C of part 1 yielded ACH = 30.15

Applying, the Sherman and Grimsrud correction for shielding for class II (correction factor=0.85 from Section 1.6), as well as correction factor (=0.85) for insect screening from step 6 of calculation procedure, the corrected air change is:

$$\begin{aligned} \text{ACH} &= 30.15 * 0.88 * 0.85 = 22.55 \\ \text{ACH measured} &= 23.3 \text{ (Chandra, 1983)} \\ \% \text{ difference} &= -3.2\% \end{aligned}$$

In summary, we can conclude that the suggested procedure is quite accurate for calculating natural ventilation airflow rates. Further verifications by other users should be performed to assess the range of applicability of this method.



## REFERENCES

- ANON. "Principles of natural ventilation." BRE Digest 210, February 1978.
- AKINS, R.E., and CERMAK, J.E. "Wind pressures on buildings." NSF Grant ENG72-04260-A01 and ENG76-03035. Fluid Mechanics and Diffusion Laboratory, College of Engineering, Colorado State University. CER76-77REA-JEC15 1976.
- AKINS, R.E., PETERKA, J.A., and CERMAK, J.E. "Average pressure coefficients for rectangular buildings, Colorado State University. Fort Collins, Colo., 1979.
- ASHLEY, S.K. "Field and Wind Tunnel Testing on Natural Ventilation Cooling Effects on Three Navy Buildings" Technical Report R-912, Naval Civil Engineering Laboratory, Port Hueneme, California 93043.
- BOWEN, A.J. "A Wind Tunnel Investigation Using Simple Building Models to Obtain Mean Surface Wind Pressure Coefficient for Air Infiltration Estimates." National Aeronautical Establishment, National research Council, Canada, Report LTR-LA-209, December 1976.
- CERMAK, J.E., PETERKA, J.A., AYAD, S.S. AND POREH, M. "Passive and Hybrid Cooling Developments: Natural Ventilation-A Wind Tunnel Study." DOE Contract No. DE-AC03-80CS11510, Fluid Dynamics and Diffusion Laboratory, Colorado State University, Fort Collins, CO, October 1981.
- CHANDRA, S. FAIREY, P, KERESTECIOGLU, A., KAMEL, A. "Wind Tunnel and Full Scale Data on Airflows from Natural Ventilation and Ceiling Fans." ASHRAE TRANSACTIONS, Vol 92, part 2, 1986.
- CHANDRA, S., HOUSTON, M., FAIREY, P. and KERESTECIOGLU, A. "Wing Walls to Improve Natural Ventilation: Full Scale Results and Design Strategies," proceedings of ASES Eighth National Passive Conference, Glorieta, NM, September 1983.
- COCKROFT, J.P. and ROBINSON, P. "Ventilation of an Enclosure Through a Single Opening," Building and Environment, Vol. 11, pp. 29-35, Pergamon Press, 1976.
- DATAPLOT, "An Interactive High-Level language for Graphics, Non-Linear fitting, Data Analysis and Mathematics." Developed by J.J.Filliben, National Bureau of Standards. (1977)
- HAMILTON, G.F. "Effects of Velocity Distribution Wind Loads on Walls and Low Buildings." Tech publication series. TP6205 November 1962, Dept of Mech Eng. Univ. of Toronto.
- HOLDO, A.E., HOUGHTON, E.L and BHINDER, F.S. Some Effects Due to Variations in Turbulence Integral Length Scales on the Pressure Distribution on Wind-Tunnel Models of Low-Rise Buildings."

Journal of Wind Engineering and Industrial Aerodynamics, Vol 10, pp. 103-115 (1982).

JENSEN, M and FRANK, N. "Model-Scale Tests in Turbulent Wind, Part II. Phenomena Dependent on the Velocity Pressure." Danish Technical Press, Copenhagen, 1965.

KELNHOFER, W.J. "Air Infiltration in Buildings Due to Wind Pressures Including Some Neighboring Body Effects." "Heat Transfer in Energy Conservation" ed. Goldstien, R.J et al. pp 47-56, (1977).

LEE, B.E., HUSSIAN, M., SOLIMAN, B. "A Method for the Assessment of the wind Induced Natural Ventilation Forces Acting on Low Rise Building Arrays." University of Sheffield, Department of Building Science, Report No BS 50 (1979).

LUSCH, G., and TRUCKENBRODT, E. "Windkanaluntersuchungen an Gebauden von rechteckigem Grundriss mit Flach- und Satteldachern." Berichte aus der Bauforschung. vol.41 p25-69 1964.

SHERMAN, M.H and GRIMSRUD, D.T. "Wind and Infiltration Interaction for Small Buildings." Annual Meeting of the American Society of Civil Engineers, New Orleans, LA, October 23-29, 1982.

SPSS-X, Data analysis system. Copyright 1986, SPSS inc., 444 N. Michigan Ave., Chicago, Illinois 60611.

TIELEMAN, H., AKINS, R.E and SPACKS P.R. "A Comparison of Wind Tunnel and Full-Scale Wind Pressure Measurements on Low-Rise Structures," 4th Colloquium on Industrial Aerodynamics. Hachen, June 19-20, 1980.

VICKERY, B.J., BADDOUR, R.E., KARAKATSANIS, C.A. "A Study of the External Wind Pressure Distributions and Induced Internal Ventilation Flow in Low-rise Industrial and Domestic Structures." Report No. BLWT-SS2-1983, Boundary Layer Wind Tunnel Laboratory University of Western Ontario, January 1983.

VICKERY, P.J AND SURRY, D. "The Aylesbury Experiments Revisited-Further Wind Tunnel Tests and Comparison," J. Wind Eng. and Industrial Aerodynamics, Vol. II Parts 1-3 (1983), pp 39-62.

WARREN, P.R. "Ventilation through openings on one wall only." Energy Conservation in Heating, Cooling and Ventilating Buildings, Vol. 1, pp. 189-206, Hemisphere Publishing Corp., 1978 .

WIREN, B.G "Effects of Surrounding Buildings on Wind Pressure Distribution and Ventilative Heat Losses for a Single-Family House." Report number M85:19 The National Swedish Institute for Building Research, December (1985).

Table 2-1  
COMPARISON OF VENTILATION RATES

Angle	Terrain	Ventilation rate		% Diff
		by local Cp	by average Cp	
0	Open	32.79	33.02	0.7%
	Suburban	35.08	35.12	0.11%
45	Open	30.34	31.19	2.79%
	Suburban	33.30	32.86	-1.32%
90	Open	18.20	19.05	4.68%
	Suburban	21.89	17.53	-19.94%

TABLE 2-2 : JENSEN (1965) , 2:1:1 , FLAT ROOF , SMALL TURBULENCE

	S: 2.000	S: 0.500
	a: 0.0	a: 0.0
	b: 0.0	b: 0.0
	CP(0): 0.500	CP(0): 0.559
AS	CP/CP(0)	CP/CP(0)
-----	-----	-----
0.0	1.000	1.000
90.0	MISSING	-1.068
110.0	-1.077	MISSING
135.0	-0.893	MISSING
180.0	-0.557	-0.215
-----	-----	-----

TABLE 2-3 : JENSEN (1965) , 2:1:1 , FLAT ROOF , LARGE TURBULENCE

	S: 2.000	S: 0.500
	a: 0.0	a: 0.0
	b: 0.0	b: 0.0
	CP(0): 0.600	CP(0): 0.616
AS	CP/CP(0)	CP/CP(0)
-----	-----	-----
0.0	1.000	1.000
95.0	MISSING	-0.758
120.0	-0.700	MISSING
180.0	-0.250	0.000
-----	-----	-----

TABLE 2-4 : JENSEN (1965) , 2:1:1 , 1:1 ROOF , LARGE TURBULENCE

	S: 2.000	S: 0.500
	a: 45.0	a: 0.0
	b: 0.0	b: 45.0
	CP(0): 0.504	CP(0): 0.441
AS	CP/CP(0)	CP/CP(0)
-----	-----	-----
0.0	1.000	1.000
90.0	MISSING	-1.259
180.0	-0.794	-0.068
-----	-----	-----

TABLE 2-5 : JENSEN (1965) , 2:1:0.5 , 1:1 ROOF , LARGE TURBULENCE

	S: 2.000	S: 0.500
	a: 45.0	a: 0.0
	b: 0.0	b: 45.0
	CP(0): 0.469	CP(0): 0.489
AS	CP/CP(0)	CP/CP(0)
-----	-----	-----
0.0	1.000	1.000
95.0	MISSING	-1.213
135.0	-1.066	MISSING
180.0	-0.896	-0.225
-----	-----	-----

TABLE 2-6 : CERMAK (1981) , 3:3:2 , 1:2 ROOF

	S: 1.000	S: 1.000
	a: 26.6	a: 26.6
	b: 26.6	b: 26.6
	CP(0): 0.398	CP(0): 0.390
AS	CP/CP(0)	CP/CP(0)
-----	-----	-----
0.0	1.000	1.000
22.5	0.889	0.956
45.0	0.563	0.554
67.5	-0.088	-0.088
90.0	-1.025	-1.000
112.5	-1.402	-1.462
135.0	-1.146	-1.177
157.5	-0.924	-0.954
180.0	-0.668	-0.708
-----	-----	-----

TABLE 2-7 : HAMILTON (1962) , 1:1:1 , FLAT ROOF , SUBURBAN

	S: 1.000	S: 1.000
	a: 0.0	a: 0.0
	b: 0.0	b: 0.0
	CP(0): 0.610	CP(0): 0.610
AS	CP/CP(0)	CP/CP(0)
-----	-----	-----
0.0	1.000	1.000
45.0	0.566	0.566
90.0	-0.916	-0.916
135.0	-0.693	-0.693
180.0	-0.316	-0.316
-----	-----	-----

TABLE 2-8 : HAMILTON (1962) , 1:1:1 , 15 DEG ROOF , SUBURBAN

	S: 1.000	S: 1.000
	a: 15.0	a: 0.0
	b: 0.0	b: 15.0
	CP(0): 0.480	CP(0): 0.515
AS	CP/CP(0)	CP/CP(0)
-----	-----	-----
0.0	1.000	1.000
45.0	0.385	0.283
90.0	-1.183	-0.860
135.0	-1.250	-1.029
180.0	-0.354	-0.344
-----	-----	-----

TABLE 2-9: HAMILTON (1962) , 1:1:1 , 30 DEG ROOF , SUBURBAN

	S: 1.000	S: 1.000
	a: 30.0	a: 0.0
	b: 0.0	b: 30.0
	CP(0): 0.419	CP(0): 0.435
AS	CP/CP(0)	CP/CP(0)
-----	-----	-----
0.0	1.000	1.000
45.0	0.640	0.708
90.0	-1.317	-1.407
135.0	-0.955	-0.839
180.0	MISSING	-0.667
-----	-----	-----

TABLE 2-10: HAMILTON (1962) , 1:1:1 , 45 DEG ROOF , SUBURBAN

	S: 1.000	S: 1.000
	a: 45.0	a: 0.0
	b: 0.0	b: 45.0
	CP(0): 0.446	CP(0): 0.438
AS	CP/CP(0)	CP/CP(0)
-----	-----	-----
0.0	1.000	1.000
45.0	0.534	0.582
90.0	-1.231	-1.345
135.0	-0.886	-0.897
180.0	-0.798	-0.639
-----	-----	-----

TABLE 2-11: VICKERY (1983) , 100:80:16, 1:12 ROOF , OPEN

	S: 1.250	S: 0.800
	a: 4.8	a: 0.0
	b: 0.0	b: 4.8
	CP(0): 0.564	CP(0): 0.518

AS	CP/CP(0)	CP/CP(0)
0.0	1.000	1.000
10.0	0.988	1.000
20.0	0.910	0.979
30.0	0.813	0.847
40.0	0.656	0.761
50.0	0.500	0.566
60.0	0.314	0.369
70.0	0.071	0.131
80.0	-0.054	-0.108
90.0	-0.174	-0.317
100.0	-0.332	-0.490
110.0	-0.443	-0.525
120.0	-0.443	-0.510
130.0	-0.447	-0.396
140.0	-0.385	-0.284
150.0	-0.316	-0.272
160.0	-0.168	-0.241
170.0	-0.122	-0.181
180.0	-0.062	-0.154

TABLE 2-12: VICKERY (1983) , 125:80 , 4:12 ROOF , OPEN

	S: 1.563	S: 0.640
	a: 18.4	a: 0.0
	b: 0.0	b: 18.4
	CP(0): 0.403	CP(0): 0.253

AS	CP/CP(0)	CP/CP(0)
0.0	1.000	1.000
45.0	0.435	0.546
90.0	-0.568	MISSING
135.0	-0.948	-1.346
180.0	-0.864	-0.715

TABLE 2-13: VICKERY (1983) , 125:80 , 1:12 ROOF , OPEN

	S: 1.563	S: 0.640
	a: 4.8	a: 0.0
	b: 0.0	b: 4.8
	CP(0): 0.448	CP(0): 0.495
AS	CP/CP(0)	CP/CP(0)
-----	-----	-----
0.0	1.000	1.000
45.0	0.543	0.480
90.0	-0.445	-0.615
135.0	-0.785	-0.482
180.0	-0.315	-0.262
-----	-----	-----

TABLE 2-14: VICKERY (1983) , 125:80 , 4:12 ROOF , SUBURBAN

	S: 1.563	S: 0.640
	a: 18.4	a: 0.0
	b: 0.0	b: 18.4
	CP(0): 0.384	CP(0): 0.281
AS	CP/CP(0)	CP/CP(0)
-----	-----	-----
0.0	1.000	1.000
45.0	0.396	0.142
90.0	-0.784	MISSING
135.0	-1.169	-1.612
180.0	-1.193	-1.004
-----	-----	-----

TABLE 2-15: VICKERY (1983) , 125:80 , 1:12 ROOF , SUBURBAN

	S: 1.563	S: 0.640
	a: 4.8	a: 0.0
	b: 0.0	b: 4.8
	CP(0): 0.394	CP(0): 0.311
AS	CP/CP(0)	CP/CP(0)
-----	-----	-----
0.0	1.000	1.000
45.0	0.459	0.469
90.0	-0.579	-1.154
135.0	-1.036	-1.039
180.0	-0.607	-0.698
-----	-----	-----



TABLE 2-16: WIREN (1983) , 130:85:32 , 45 DEG ROOF , OPEN

S: 1.53	S: 0.654
a: 45.0	a: 0.0
b: 0.0	b: 45.0
CP(0): 0.502	CP(0): 0.571

AS	CP/CP(0)	CP/CP(0)
0.0	1.000	1.000
15.0	0.958	0.925
22.5	0.882	0.856
30.0	0.779	0.750
45.0	0.470	0.373
60.0	0.020	-0.152
67.5	-0.235	-0.480
75.0	-0.504	-0.839
90.0	-0.968	-1.511
105.0	-1.307	-1.704
112.5	-1.398	-1.557
120.0	-1.462	-1.396
135.0	-1.538	-1.123
150.0	-1.418	-0.972
157.5	-1.369	-0.893
165.0	-1.375	-0.778
180.0	-1.363	-0.578

TABLE 2-17: LUSCH (1964) , 4:2:1 , FLAT ROOF

	S: 2.000	S: 0.500
	a: 0.0	a: 0.0
	b: 0.0	b: 0.0
	CP(0): 0.314	CP(0): 0.300
AS	CP/CP(0)	CP/CP(0)
0.0	1.000	1.000
22.5	1.000	0.933
45.0	0.732	0.667
62.5	0.274	0.000
90.0	-0.274	-0.967
112.5	-0.860	-1.333
135.0	-1.092	-0.767
157.5	-0.592	-0.567
180.0	-0.455	-0.333

TABLE 2-18: LUSCH (1964) , 4:2:1 , 10 DEG ROOF

	S: 2.000	S: 0.500
	a: 10.0	a: 0.0
	b: 0.0	b: 10.0
	CP(0): 0.300	CP(0): 0.290
AS	CP/CP(0)	CP/CP(0)
0.0	1.000	1.000
22.5	0.900	0.931
45.0	0.900	0.621
62.5	0.233	0.069
90.0	-0.333	-0.931
112.5	-0.900	-1.345
135.0	-1.000	-0.862
157.5	-0.620	-0.621
180.0	-0.477	-0.310

TABLE 2-19: LUSCH (1964) , 4:2:1 , 20 DEG ROOF

	S: 2.000	S: 0.500
	a: 20.0	a: 0.0
	b: 0.0	b: 20.0
	CP(0): 0.300	CP(0): 0.310
AS	CP/CP(0)	CP/CP(0)
0.0	1.000	1.000
22.5	1.000	0.935
45.0	0.667	0.710
62.5	0.287	-0.097
90.0	-0.380	-1.000
112.5	-0.900	-1.129
135.0	-1.093	-0.839
157.5	-0.857	-0.645
180.0	-0.667	-0.355

TABLE 2-20: LUSCH (1964) , 4:2:1 , 30 DEG ROOF

	S: 2.000	S: 0.500
	a: 30.0	a: 0.0
	b: 0.0	b: 30.0
	CP(0): 0.370	CP(0): 0.310
AS	CP/CP(0)	CP/CP(0)
0.0	1.000	1.000
22.5	0.784	0.968
45.0	0.595	0.613
62.5	0.216	-0.032
90.0	-0.270	-1.194
112.5	-0.730	-1.387
135.0	-1.000	-0.903
157.5	-0.811	-0.645
180.0	-0.730	-0.323

TABLE 2-21: LUSCH (1964) , 4:2:1 , 40 DEG ROOF

	S: 2.000	S: 0.500
	a: 40.0	a: 0.0
	b: 0.0	b: 40.0
	CP(0): 0.330	CP(0): 0.360
AS	CP/CP(0)	CP/CP(0)
0.0	1.000	1.000
22.5	0.939	0.889
45.0	0.697	0.500
62.5	0.212	-0.167
90.0	-0.394	-1.167
112.5	-0.909	-1.333
135.0	-1.303	-0.917
157.5	-0.970	-0.667
180.0	-0.909	-0.278

TABLE 2-22: LUSCH (1964) , 4:2:1 , 60 DEG ROOF

	S: 2.000	S: 0.500
	a: 60.0	a: 0.0
	b: 0.0	b: 60.0
	CP(0): 0.386	CP(0): 0.450
AS	CP/CP(0)	CP/CP(0)
0.0	1.000	1.000
22.5	0.982	0.889
45.0	0.733	0.444
62.5	0.179	-0.400
90.0	-0.394	-1.333
112.5	-1.215	-1.156
135.0	-1.295	-0.889
157.5	-1.091	-0.600
180.0	-1.036	-0.244

TABLE 2-23: ASHLEY (1984) , 8:1:0.5 , FLAT ROOF , SUBURBAN

S:	8.000	S:	0.125
a:	0.0	a:	0.0
b:	0.0	b:	0.0
CP(0):	0.630	CP(0):	0.690

AS	CP/CP(0)	CP/CP(0)
0.0	1.000	1.000
10.0	0.841	MISSING
20.0	MISSING	0.855
30.0	0.683	MISSING
40.0	MISSING	0.710
45.0	0.540	0.609
50.0	0.508	MISSING
60.0	MISSING	0.362
70.0	0.198	MISSING
80.0	MISSING	-0.181
90.0	-0.047	-0.855
100.0	MISSING	-0.768
110.0	-0.222	MISSING
120.0	MISSING	-0.609
130.0	-0.397	MISSING
135.0	-0.444	-0.493
140.0	MISSING	-0.449
150.0	-0.492	MISSING
160.0	MISSING	-0.275
170.0	-0.556	MISSING
180.0	-0.444	-0.130

TABLE 2-24: ASHLEY (1984) , 10:3:1.5 , 20 DEG ROOF , SUBURBAN

S: 3.330	S: 0.300
a: 20.0	a: 22.0
b: 22.0	b: 20.0
CP(0): 0.547	CP(0): 0.590

AS	CP/CP(0)	CP/CP(0)
0.0	1.000	1.000
15.0	0.885	MISSING
30.0	0.857	0.356
45.0	0.572	0.220
60.0	0.115	-0.085
75.0	MISSING	-0.525
90.0	-0.194	-0.847
105.0	MISSING	-0.636
120.0	-0.146	-0.239
135.0	-0.311	-0.107
150.0	-0.400	-0.136
165.0	-0.439	MISSING
180.0	-0.530	-0.053

TABLE 2-25: ASHLEY (1984) , 2.7:1:0.5 , 24 DEG ROOF , SUBURBAN

S: 2.780	S: 0.360
a: 24.0	a: 22.0
b: 22.0	b: 24.0
CP(0): 0.719	CP(0): 1.063

AS	CP/CP(0)	CP/CP(0)
0.0	1.000	1.000
5.0	MISSING	0.882
10.0	0.978	MISSING
15.0	0.935	0.941
20.0	0.847	MISSING
30.0	0.826	0.794
40.0	0.804	MISSING
45.0	0.565	0.500
50.0	MISSING	0.324
60.0	0.305	0.088
70.0	MISSING	0.073
75.0	0.088	-0.118
80.0	MISSING	-0.264
85.0	-0.196	MISSING
90.0	-0.250	-0.713
95.0	-0.261	MISSING
100.0	MISSING	-0.382
105.0	-0.544	MISSING
110.0	MISSING	-0.338
120.0	-0.609	-0.300
130.0	MISSING	-0.344
135.0	-0.609	-0.353
140.0	-0.565	MISSING
150.0	-0.533	-0.264
160.0	-0.587	MISSING
165.0	-0.499	-0.191
170.0	-0.478	MISSING
175.0	MISSING	-0.088
180.0	-0.522	-0.073

TABLE 2-26: AKINS (1979) , 1:1 , FLAT ROOF , SUBURBAN

S: 1.000	S: 1.000
a: 0.0	a: 0.0
b: 0.0	b: 0.0
CP(0): 0.613	CP(0): 0.613

AS	CP/CP(0)	CP/CP(0)
0.0	1.000	1.000
10.0	MISSING	0.930
15.0	MISSING	0.966
20.0	0.966	0.896
25.0	MISSING	0.930
30.0	MISSING	0.827
35.0	MISSING	0.793
40.0	0.654	0.654
50.0	0.414	0.449
55.0	0.276	MISSING
60.0	0.069	MISSING
65.0	-0.103	MISSING
70.0	-0.344	-0.310
75.0	-0.551	MISSING
80.0	-0.793	MISSING
90.0	-1.000	-1.000
100.0	-1.000	MISSING
105.0	-0.966	MISSING
110.0	-0.930	-0.930
115.0	-0.930	MISSING
120.0	-0.861	MISSING
125.0	-0.861	MISSING
130.0	-0.793	-0.793
140.0	-0.654	-0.654
145.0	MISSING	-0.654
150.0	MISSING	-0.620
155.0	MISSING	-0.586
160.0	-0.551	-0.586
165.0	MISSING	-0.586
170.0	MISSING	-0.586
180.0	-0.449	-0.517



TABLE 2-27: AKINS (1979) , 2:1 , FLAT ROOF , SUBURBAN

S: 2.000	S: 0.500
a: 0.0	a: 0.0
b: 0.0	b: 0.0
CP(0): 0.613	CP(0): 0.613

AS	CP/CP(0)	CP/CP(0)
0.0	1.000	1.000
10.0	MISSING	1.000
15.0	MISSING	1.000
20.0	0.930	0.930
25.0	MISSING	0.861
30.0	MISSING	0.793
35.0	MISSING	0.654
40.0	0.654	0.483
50.0	0.483	0.207
55.0	0.344	MISSING
60.0	0.207	MISSING
65.0	0.034	MISSING
70.0	-0.069	-0.793
75.0	-0.241	MISSING
80.0	-0.378	MISSING
90.0	-0.724	-1.137
100.0	-0.930	MISSING
105.0	-0.966	MISSING
110.0	-0.966	-0.930
115.0	-1.000	MISSING
120.0	-1.000	MISSING
125.0	-1.000	MISSING
130.0	-0.930	-0.724
140.0	-0.861	-0.724
145.0	MISSING	-0.724
150.0	MISSING	-0.654
155.0	MISSING	-0.620
160.0	-0.724	-0.586
165.0	MISSING	-0.517
170.0	MISSING	-0.449
180.0	-0.724	-0.310

TABLE 2-28: AKINS (1979) , 4:1 , FLAT ROOF , SUBURBAN

S: 4.000	S: 0.250
a: 0.0	a: 0.0
b: 0.0	b: 0.0
CP(0): 0.613	CP(0): 0.613

AS	CP/CP(0)	CP/CP(0)
0.0	1.000	1.000
10.0	MISSING	0.930
15.0	MISSING	0.930
20.0	0.930	0.861
25.0	MISSING	0.793
30.0	MISSING	0.724
35.0	MISSING	0.551
40.0	0.724	0.378
50.0	0.517	-0.034
55.0	0.414	MISSING
60.0	0.310	MISSING
65.0	0.173	MISSING
70.0	0.103	-1.206
75.0	-0.034	MISSING
80.0	-0.139	MISSING
90.0	-0.449	-1.137
100.0	-0.793	MISSING
105.0	-0.861	MISSING
110.0	-0.930	-0.793
115.0	-0.930	MISSING
120.0	-0.930	MISSING
125.0	-0.930	MISSING
130.0	-0.930	-0.759
140.0	-0.896	-0.690
145.0	MISSING	-0.645
150.0	MISSING	-0.620
155.0	MISSING	-0.551
160.0	-0.793	-0.517
165.0	MISSING	-0.378
170.0	MISSING	-0.344
180.0	-0.861	-0.276

Table 2-29  
Correlation and regression coefficients for LOW-RISE buildings

RSQARE (actual) % Change	0.629	0.745 18.4%	0.766 2.82%	0.744 1.04%	0.788 1.81%	0.789 0.13%	0.794 0.63%	0.803 1.13%	0.808 0.62%	0.811 0.37%	0.815 0.49%
CONSTANT	2.619384	2.834603	2.835955	1.574479	1.602018	1.635214	1.644102	1.294038	1.279574	1.307114	1.450100
SIN(AS/2)	-2.370548	-2.205553	-2.04433	-1.023183	-1.093866	-1.089556	-1.084352	-0.698260	-0.705340	-0.708410	-0.855139
SIN <sup>2</sup> (AS)		-0.721645	0.724346	-1.193476	-1.177473	-1.173780	-1.176682	-1.174446	-1.181216	-1.164793	-1.128524
SIN <sup>3</sup> (2*AS*G)			0.126313	0.128441	0.131752	0.137353	0.121631	0.121089	0.123548	0.124944	0.126965
COS(AS/2)				1.192715	1.170709	1.136922	1.128350	0.731876	0.724395	0.714973	0.629153
G <sup>2</sup> *SIN <sup>3</sup> (2*AS*G)					-0.066074	0.058893	0.054233	0.058926	0.147844	0.171981	0.165756
SIN(AS/2)*a/180						-2.544006	-3.424086	-3.392773	-3.447381	-3.287165	-3.195447
SIN(AS*G)							0.054148	0.054437	0.053162	0.051999	0.049349
COS <sup>2</sup> (AS/2)								0.707523	0.729678	0.711341	0.654477
G <sup>4</sup> *SIN <sup>4</sup> (AS/2)									-0.027151	-0.033961	-0.032746
SIN <sup>4</sup> (AS*G)										-0.080427	-0.090668
G <sup>2</sup> *SIN <sup>3</sup> (2*AS*G)											0.061365

NOTE:

AS = Wind angle

G = LN(S)

S = Side Ratio

a = Roof angle of the wall for which Cp is required

Table 2-30  
Correlation and regression coefficients for LOW-RISE buildings

RSQARE (actual)	0.629	0.745	0.766	0.744	0.788	0.797	0.802	0.807	0.811
% Change		18.4%	2.82%	1.04%	1.81%	1.14%	0.62%	0.62%	0.49%
CONSTANT	2.619384	2.834603	2.835955	1.574479	1.602018	1.247746	1.232712	1.266623	1.433726
SIN(AS/2)	-2.370548	-2.205553	-2.204433	-1.023183	-1.093866	-0.702627	-0.709251	-0.712771	-0.882686
SIN <sup>2</sup> (AS)		-0.721645	-0.724346	-1.193476	-1.177473	-1.175139	-1.181885	-1.163096	-1.121153
SIN <sup>3</sup> (2*AS*G)			0.126313	0.128441	0.131752	0.131368	0.133236	0.134797	0.136367
COS(AS/2)				1.192715	1.170709	0.768545	0.761790	0.749147	0.648414
G <sup>2</sup> *SIN <sup>2</sup> (AS/2)					0.066074	0.070752	0.157220	0.184352	0.176530
COS <sup>2</sup> (AS/2)						0.716893	0.738885	0.717380	0.651371
G <sup>4</sup> *SIN <sup>4</sup> (AS/2)							-0.026372	-0.034194	-0.032733
SIN <sup>4</sup> (AS*G)								-0.091346	-0.102888
SIN <sup>4</sup> (3*AS*G)									0.071215

NOTE:  
As=Wind angle  
G=LN(S)  
S=Side Ratio

Table 2-31

Cp at Zero Incidence Referenced to Eave Height

L:W:H	Model Roof	Terrain	Source		longwall	shortwall
2:1:1	flatroof,	Open	JENSEN	(1965)	.500	.559
2:1:1	flatroof,	Industrial	JENSEN	(1965)	.600	.616
2:1:1	1:1 roof,	Open	JENSEN	(1965)	.592	.599
2:1:1	1:1 roof,	Industrial	JENSEN	(1965)	.685	.599
2:1:0.5	1:1 roof,	Industrial	JENSEN	(1965)	.913	.952
36:36:24	1:2 roof		CERMAK	(1981)	.621	.609
1:1:1	flat roof,	Suburban	HAMILTON	(1962)	.610	.610
1:1:1	15 deg roof	"	HAMILTON	(1962)	.511	.548
1:1:1	30 deg roof	"	HAMILTON	(1962)	.476	.493
1:1:1	45 deg roof	"	HAMILTON	(1962)	.546	.536
100:80	1:12 roof	Open	VICKERY	(1983)	.564	.518
125:80	4:12 roof	Open	VICKERY	(1983)	.403	.253
125:80	1:12 roof	Open	VICKERY	(1983)	.448	.495
125:80	12:12 roof	Open	VICKERY	(1983)	.479	.186
125:80	4:12 roof	Suburban	VICKERY	(1983)	.384	.281
125:80	1:12 roof	Suburban	VICKERY	(1983)	.394	.311
125:80	12:12 roof	Suburban	VICKERY	(1983)	.523	.168
130:85:32	1:1 roof	Open	WIREN	(1985)	.635	.722
4:2:1	0 deg roof		LUSCH	(1964)	.628	.600
4:2:1	10 deg roof		LUSCH	(1964)	.600	.580
4:2:1	20 deg roof		LUSCH	(1964)	.600	.620
4:2:1	30 deg roof		LUSCH	(1964)	.740	.620
4:2:1	40 deg roof		LUSCH	(1964)	.660	.720
4:2:1	60 deg roof		LUSCH	(1964)	.772	.900
8:1:0.5	Flat roof	Suburban	ASHLEY	(1984)	.690	.630
10:3:1.5	20 deg roof	Suburban	ASHLEY	(1984)	.727	.674
2.7:1:0.5	24 deg roof	Suburban	ASHLEY	(1984)	1.209	.817
1:1	Flat roof	Suburban	AKINS	(1979)	.613	.613
2:1	Flat roof	Suburban	AKINS	(1979)	.613	.613
4:1	Flat roof	Suburban	AKINS	(1979)	.613	.613

Note: Where building height is not specified, the Cp was obtained at by averaging the data from models of same side ratio but different heights.

Table 2-32

Correlation and regression coefficients for tall buildings performed independently for each side ratio

Parameter	SIDE RATIOS				
	1.0	2.0	4.0	0.50	0.25
CONSTANT	0.115354	0.370365	0.284795	-0.152602	-0.332144
Ar	-0.810597	-0.990288	-1.034506	-0.768690	-0.652721
COS(2*AS)	0.816615	0.551388	0.327888	1.051778	1.131931
ZH*SIN(AS)	0.946312	0.654536	0.401398	1.310474	1.403394
SIN(2*AS)	0.357707	0.506786	0.497753	0.260309	0.067171
ZH*COS(AS)	-0.780888	-1.098184	-1.120966	-0.686740	-0.369464
Xr*SIN(AS)	0.407320	0.505426	0.432464	0.403723	0.213580
XL	-0.431892	-0.425427	-0.383976	-0.501681	-0.386374
COS(Xr)	1.078431	1.306449	1.604759	1.124891	0.941828
COS(AS*Xr)	-0.233438	-0.304055	-0.307340	-0.252906	-0.219432
R_SQUARE	0.91240	0.90407	0.87994	0.91118	0.90879

## NOTES:

-----

AS = Wind Angle

Ar = AS\*PI/180.0 ; PI = 3.1415

Xr = (X-0.5)/0.5

Table 2-33  
Correlation and regression coefficients for tall buildings using all of Akins' data

RSQUARE(actual)	0.45281	0.73834	0.79043	0.81208	0.83078	0.85910	0.86371	0.86808	0.87365	0.88259	0.88613	0.89080	0.89121
CONSTANT	0.63255	0.63256	0.33279	0.35782	0.20815	0.61340	0.14704	-0.14202	-0.11942	-0.14651	-0.14651	0.06883	0.06759
Ar	-0.60357	-0.60357	-0.60357	-0.60357	-0.50828	-0.76627	-0.76627	-0.83948	-0.83871	-0.83880	-0.83880	-0.83880	-0.83891
COS(2AS)	0.58082	0.81257	1.43988	1.43988	1.43988	1.43988	1.42403	1.39768	1.68147	1.68147	1.68147	1.68147	1.73336
S <sup>0.169</sup> *ZH*SIN(AS)	0.99009	0.89319	0.89319	0.89319	0.89319	0.89319	0.89778	0.83717	-1.22740	-1.22740	-1.22740	-1.22740	-1.55597
S <sup>0.279</sup> *COS(2AS)	-0.63015	-0.60315	-0.63015	-0.63015	-0.63015	-0.63015	-0.63021	-0.61593	-0.87227	-0.87227	-0.87227	-0.87227	-0.92229
SIN(2AS)	0.25145	0.33390	0.33390	0.34278	0.34316	0.34371	0.34371	0.34371	0.34371	0.34371	0.34371	0.34371	0.34358
ZH*COS(AS)	-0.80145	-0.80145	-0.80133	-0.80108	-0.80079	-0.80079	-0.80079	-0.80079	-0.80079	-0.80079	-0.80079	-0.80079	-0.80087
COS(Xr)	0.53492	1.18733	1.17825	1.17659	1.17659	1.17659	1.17659	1.17659	1.17659	1.17659	1.17659	1.17659	1.11771
COS(Xr*AS)	-0.25765	-0.63586	-1.07871	-1.07871	-1.07871	-1.07871	-1.07871	-1.07871	-1.07871	-1.07871	-1.07871	-1.07871	-0.96129
S <sup>0.245</sup> *COS(Xr*AS)	0.37296	0.80619	0.80619	0.80619	0.80619	0.80619	0.80619	0.80619	0.80619	0.80619	0.80619	0.80619	0.69086
ZH*SIN(AS)	2.1812	2.1812	2.1812	2.51477									
Xr*SIN(AS)	0.14205	0.39927	0.39927										
XL	-0.43069	-0.43069											
S <sup>0.85</sup> *COS(Xr)	0.04589												

NOTES :

AS = Wind angle  
 Ar = AS\*PI/180.0 , PI = 3.1415  
 S = Side Ratio  
 Xr = (XL-0.5)/0.5

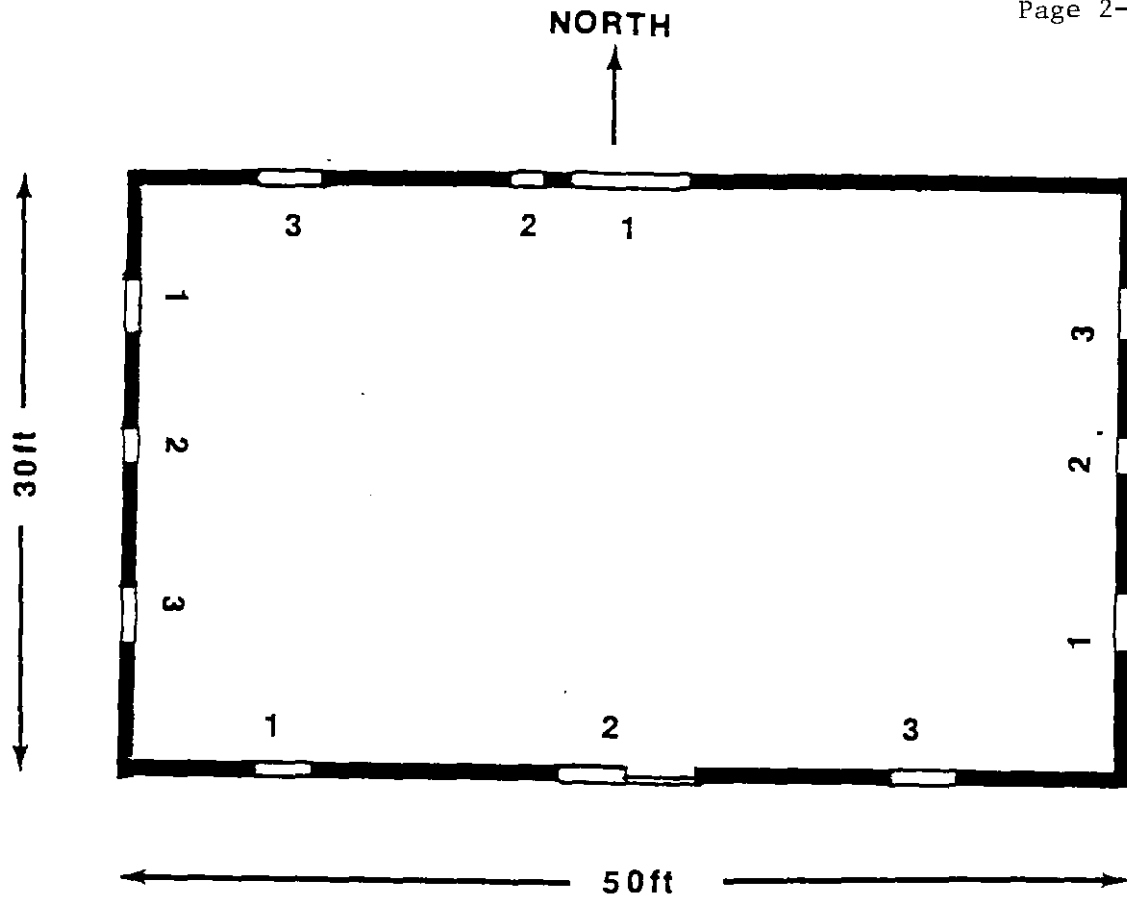

Wall	Window	Area ft <sup>2</sup>	Location of * Effective Opening		Type
			X	Y	
South	1	14	8	3.25	Single hung TOP fixed
	2	42	26	3.25	Right opening, sliding
	3	14	40	3.25	Single hung TOP fixed
West	1	18	8	3.0	"
	2	6	6	4.5	"
	3	18	22	3.0	"
North	1	32	25	3.0	"
	2	10	31	4.0	"
	3	18	42	3.0	"
East	1	18	8	3.0	"
	2	6	6	4.5	"
	3	18	22	3.0	"

\* Coordinates measured with respect to bottom left corner of wall.

Figure 2-1 Plan of base building showing windows and table showing window areas and locations



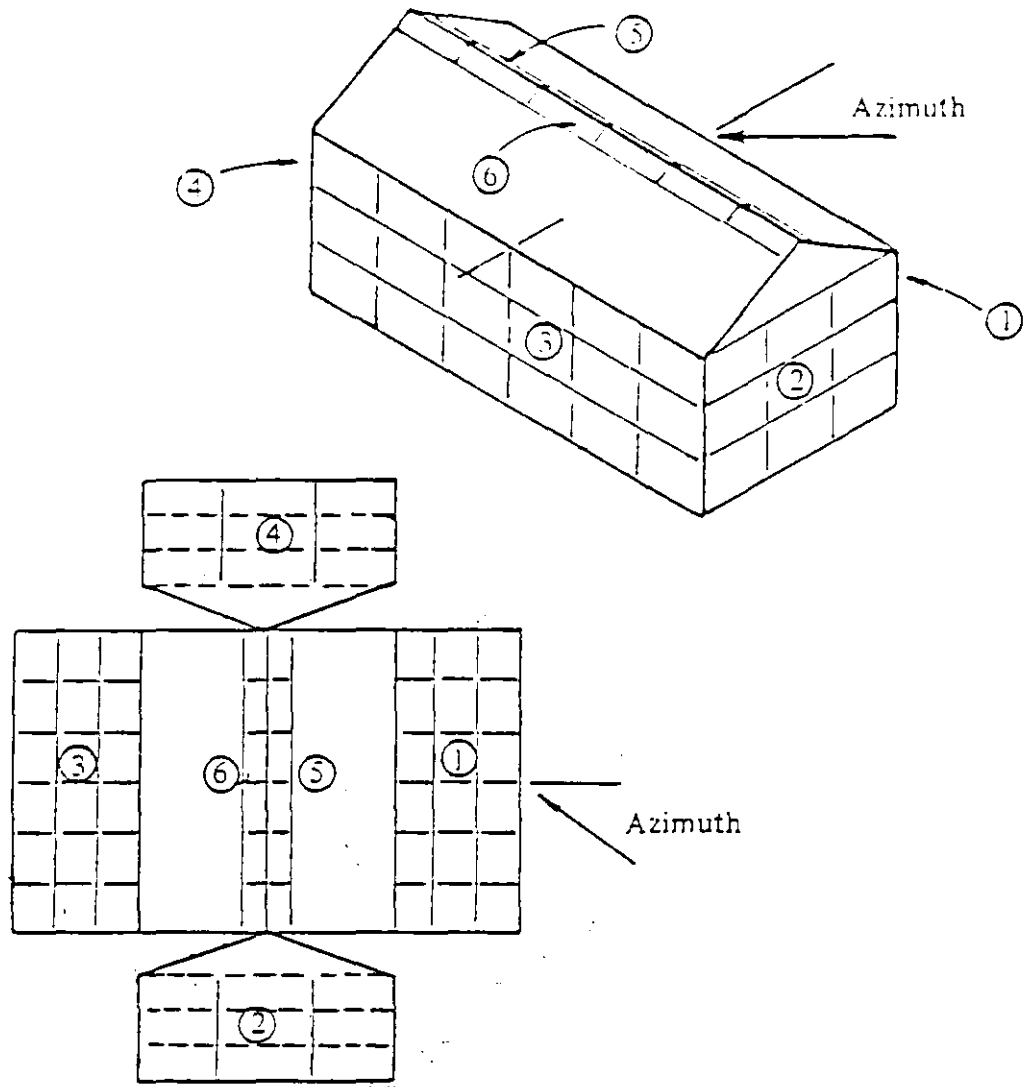

ZONING PATTERN

AZIMUTH: D

DATA

			④				
			-0.037	-0.119	-0.212		
			-0.051	-0.149	-0.231		
			-0.064	-0.176	-0.241		
-0.101	-0.101	-0.101	-0.260	-0.280	0.574	0.574	0.574
0.000	0.000	0.000	-0.311	-1.048	0.608	0.608	0.608
0.000	③ 0.000	0.000	-0.311	-1.115	0.574	0.574	0.574
-1.010	-0.010	-0.010	⑥ -0.311	-1.115	⑤ 0.608	① 0.574	0.544
-0.061	-0.061	-0.061	-1.204	-0.294	0.574	0.547	0.517
-0.047	-0.014	-0.047	-0.304	-0.159	0.591	0.564	0.365
			-0.034	-0.068	-0.138		
			-0.034	-0.068	-0.138		
			-0.034	-0.068	-0.138		
			②				

FIG.2-2 Zoning pattern and data layout ( from Vickery)

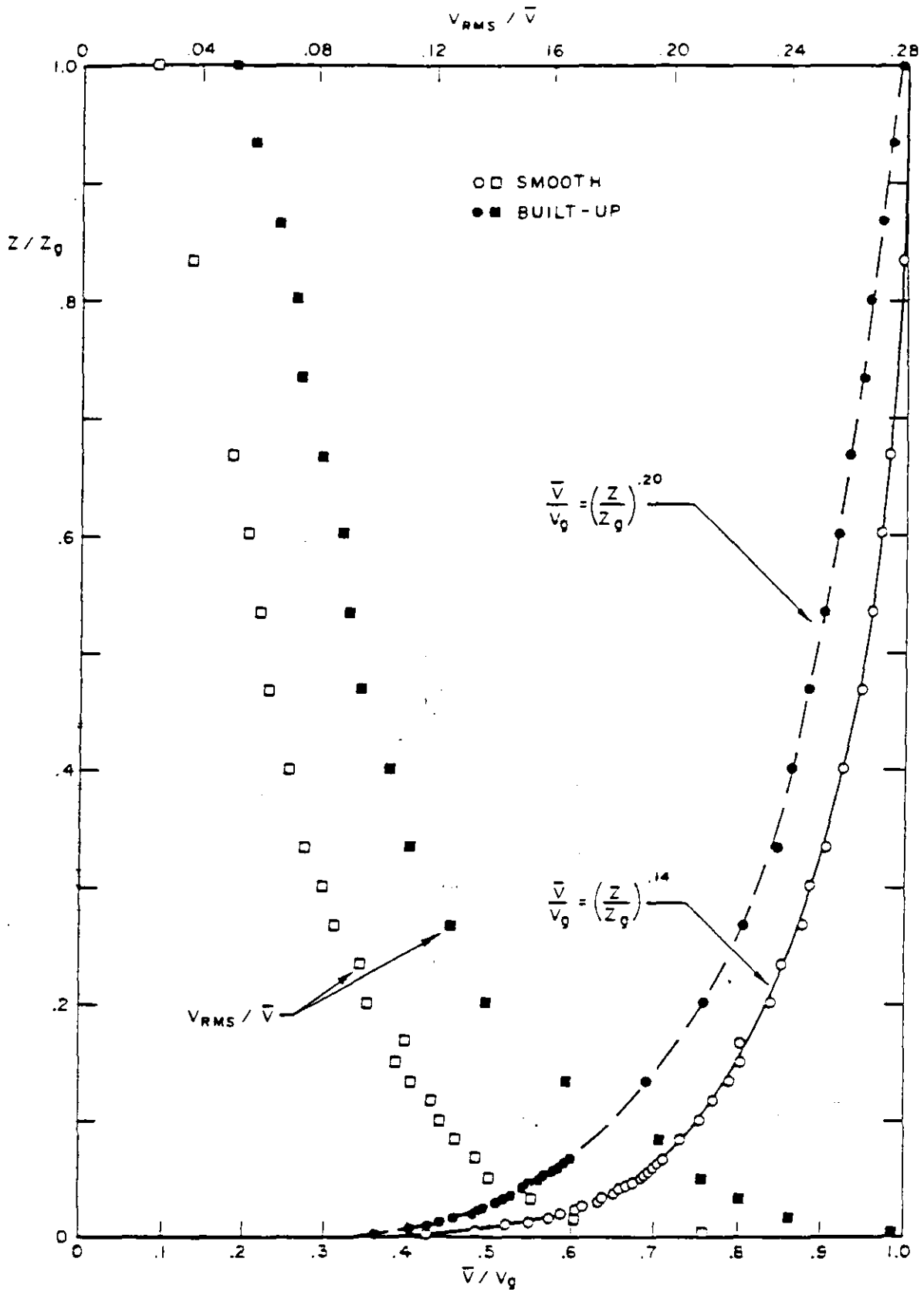

FIG. 2-3 MEAN SPEED AND TURBULENCE INTENSITY PROFILES FOR THE TWO TERRAINS CONSIDERED (From Vickery)

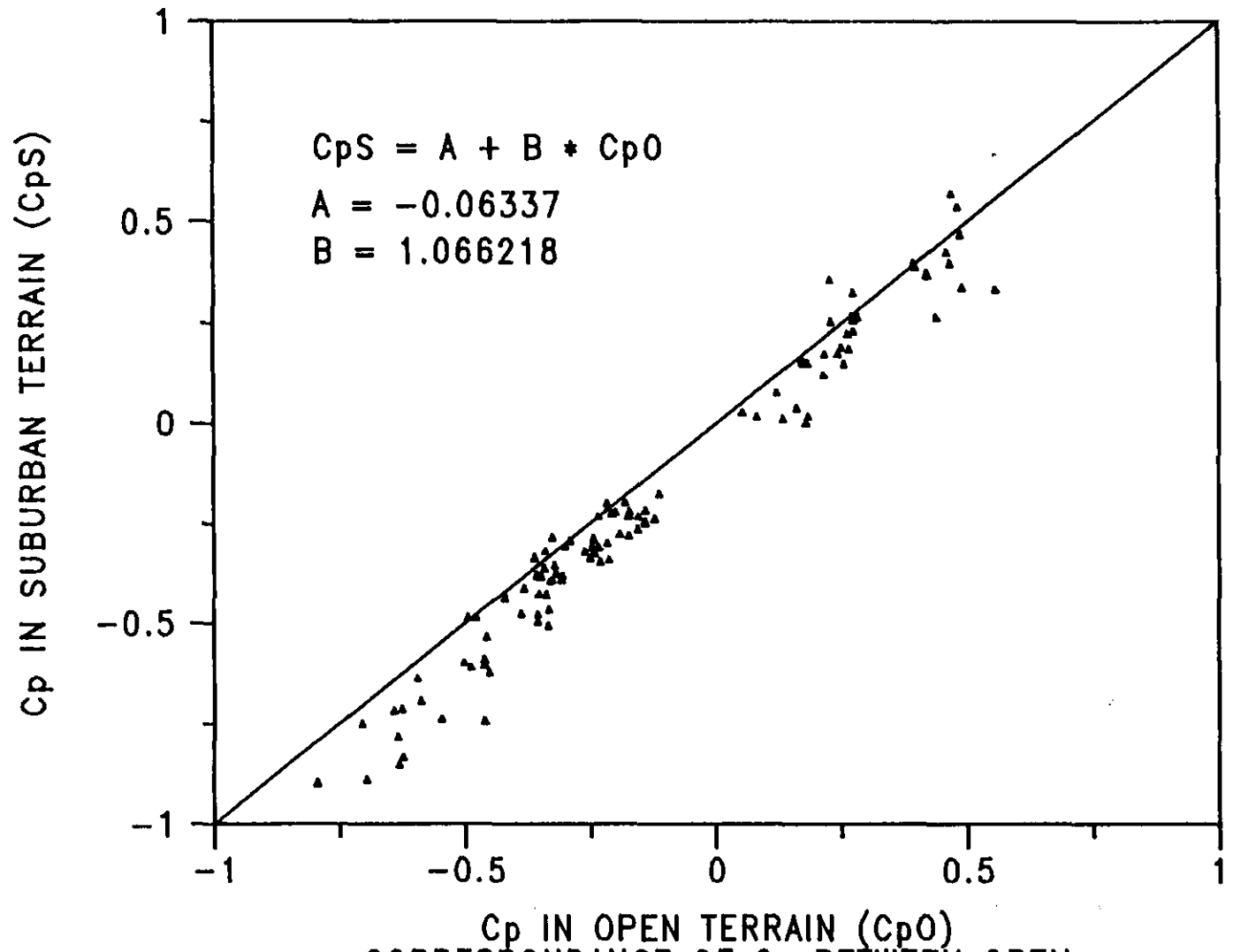
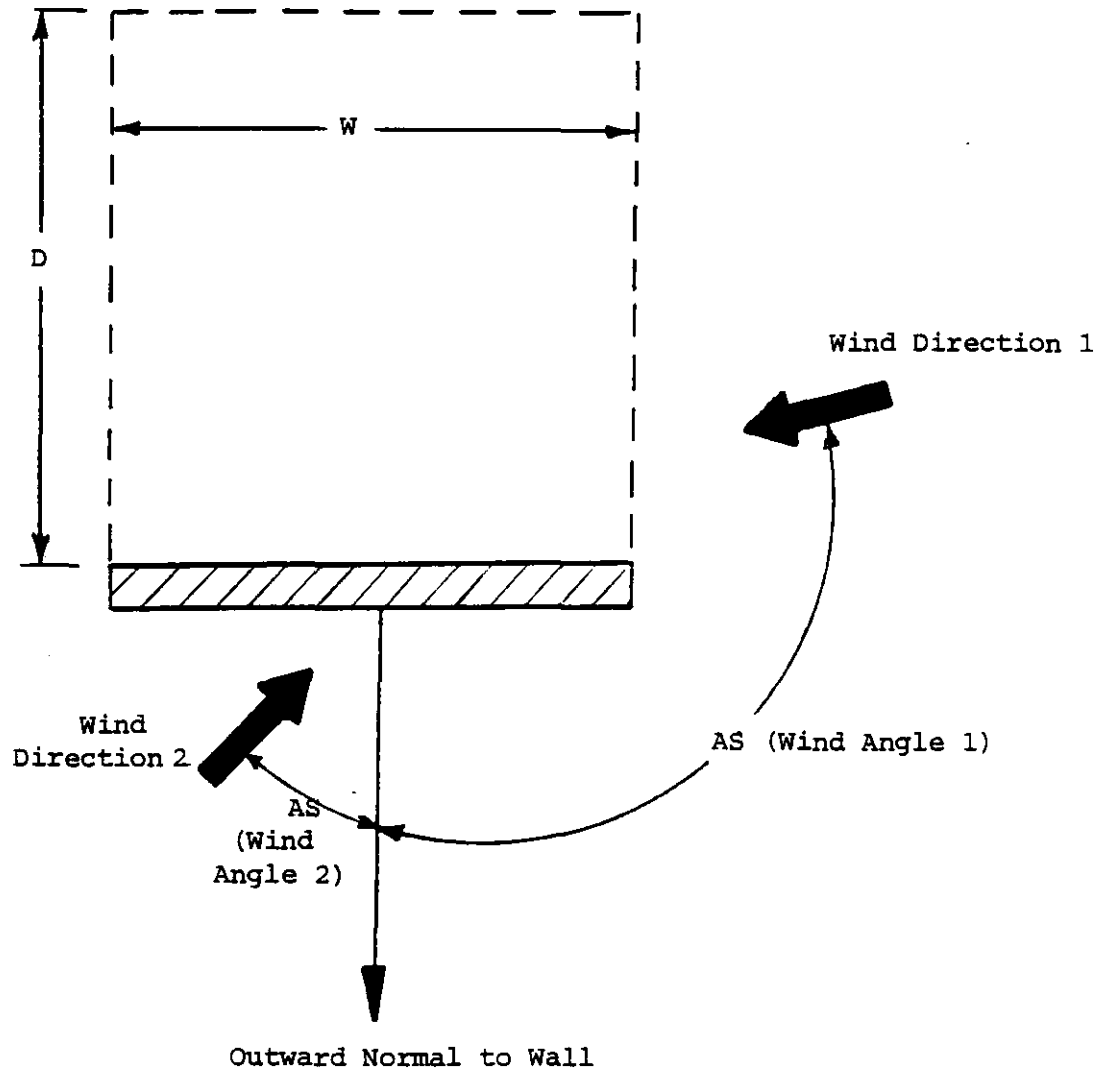
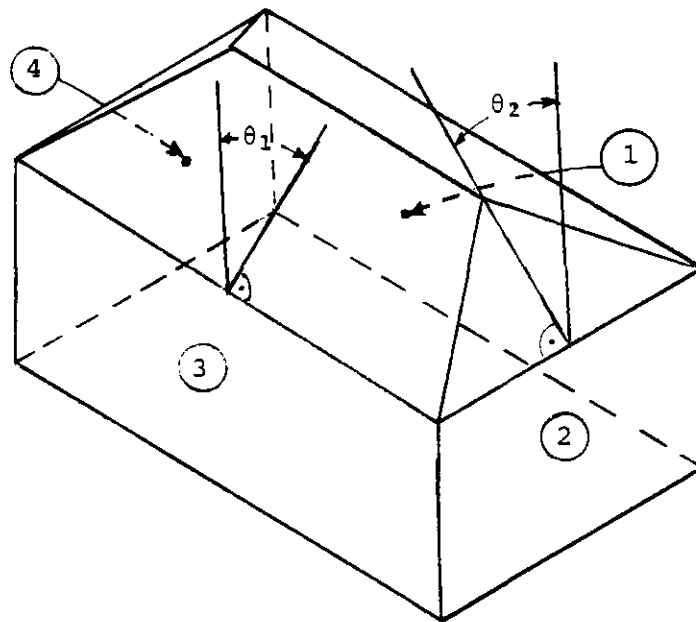

FIG. 2-4: CORRESPONDANCE OF  $C_p$  BETWEEN OPEN AND SUBURBAN TERRAINS (FROM VICKERY )



AS : is the angle between the wind direction and outward normal to the wall  
 S : Side Ratio , defined as  $W/D$  where  
 W : is the width of the wall and,  
 D : is the width of the adjacent wall

Figure 2-5 Wind Angle (AS) and Side Ratio (S) Convention



For Walls 1 and 3      $a = \theta_1$   
                              $b = \theta_2$

For Walls 2 and 4      $a = \theta_2$   
                              $b = \theta_1$

Figure 2-6 Conventions used in Defining Roof Slopes for each Wall

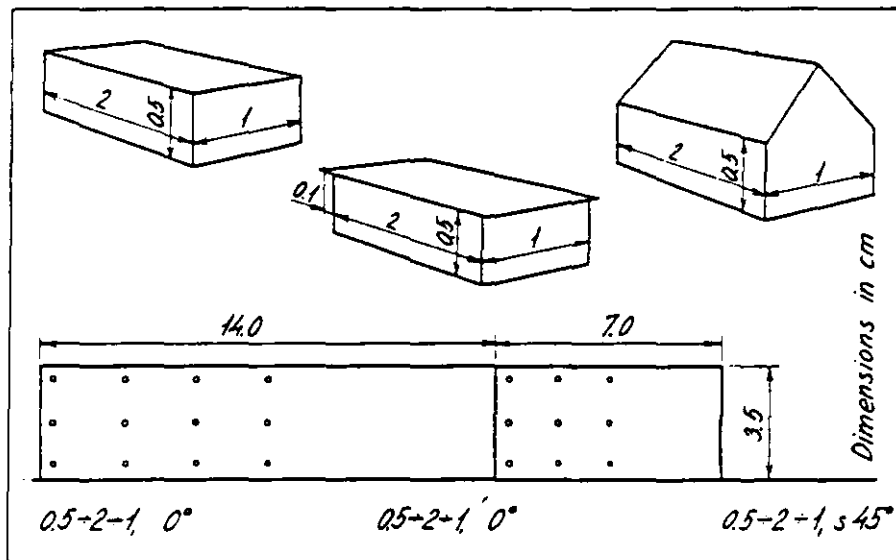
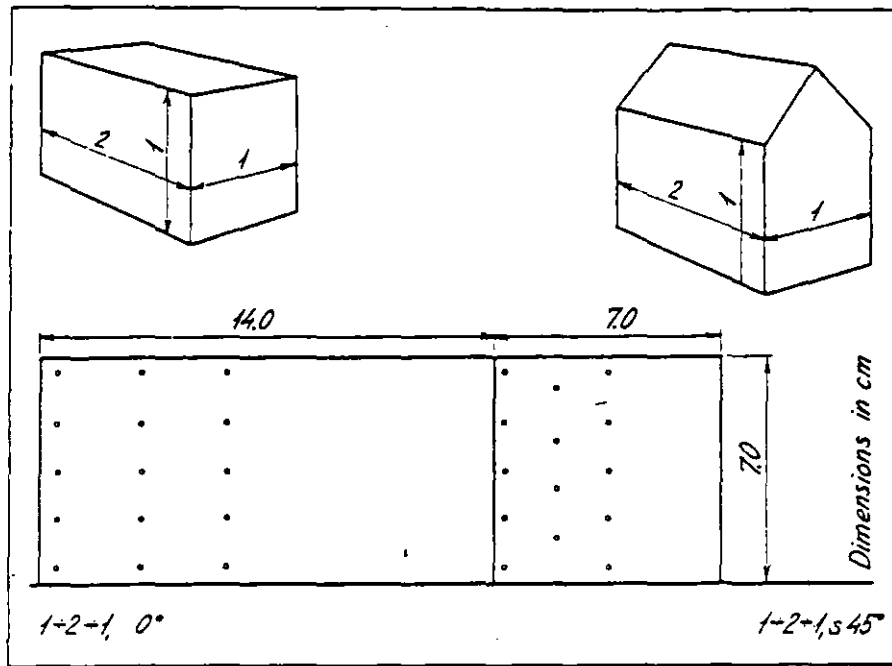

JENSEN and FRANK (1965)

Figure 2-7a: Models used in wind tunnel studies from which data were gathered.

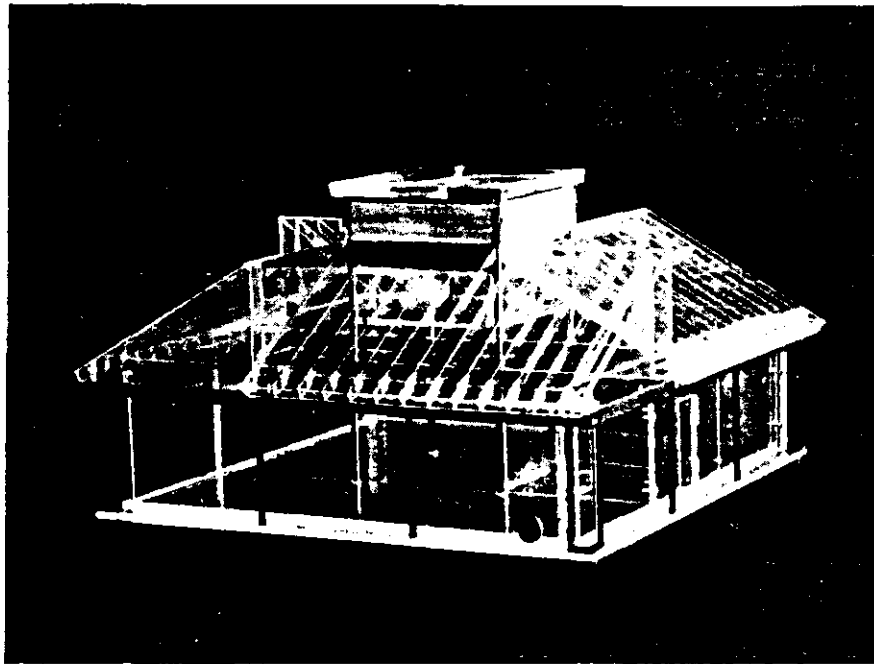

(i) CERMAK et. al. (1981)

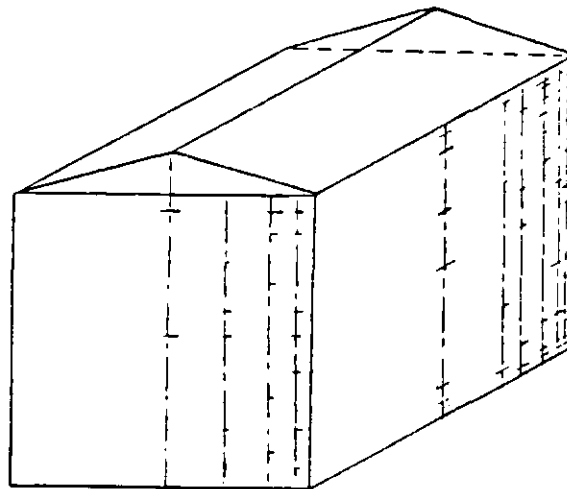

(ii) HAMILTON (1962)

Figure 2-7b: Model s used in wind tunnel studies from which data were gathered.

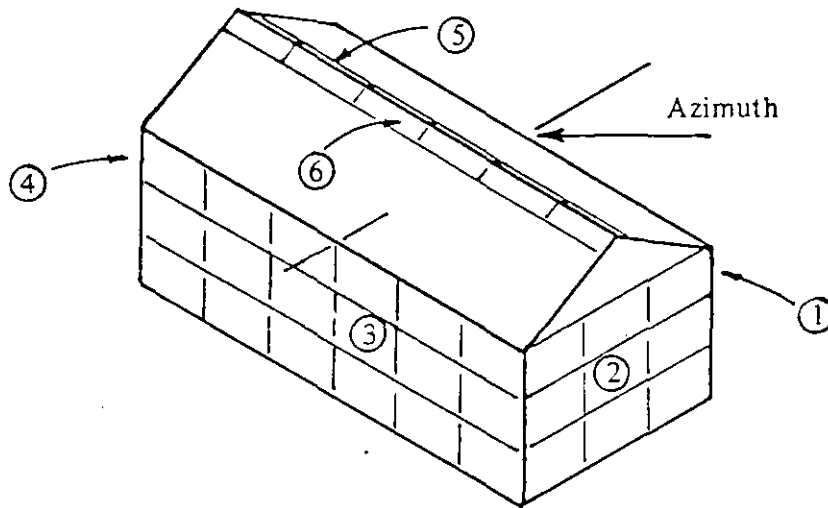

(i) VICKERY (1983)

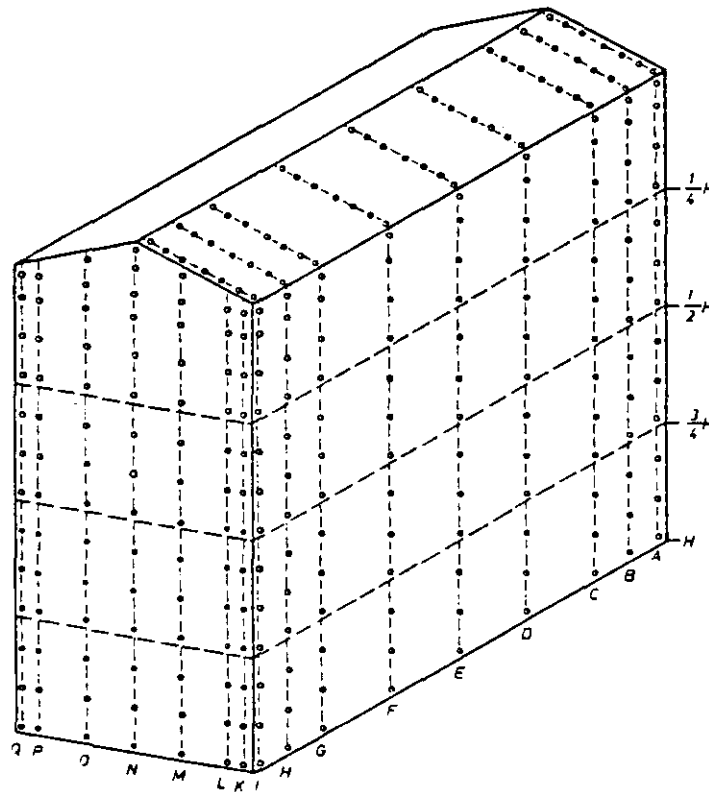

(ii) LUSCH (1964)

Figure 2-7c: Models used in wind tunnel studies from which data were gathered.



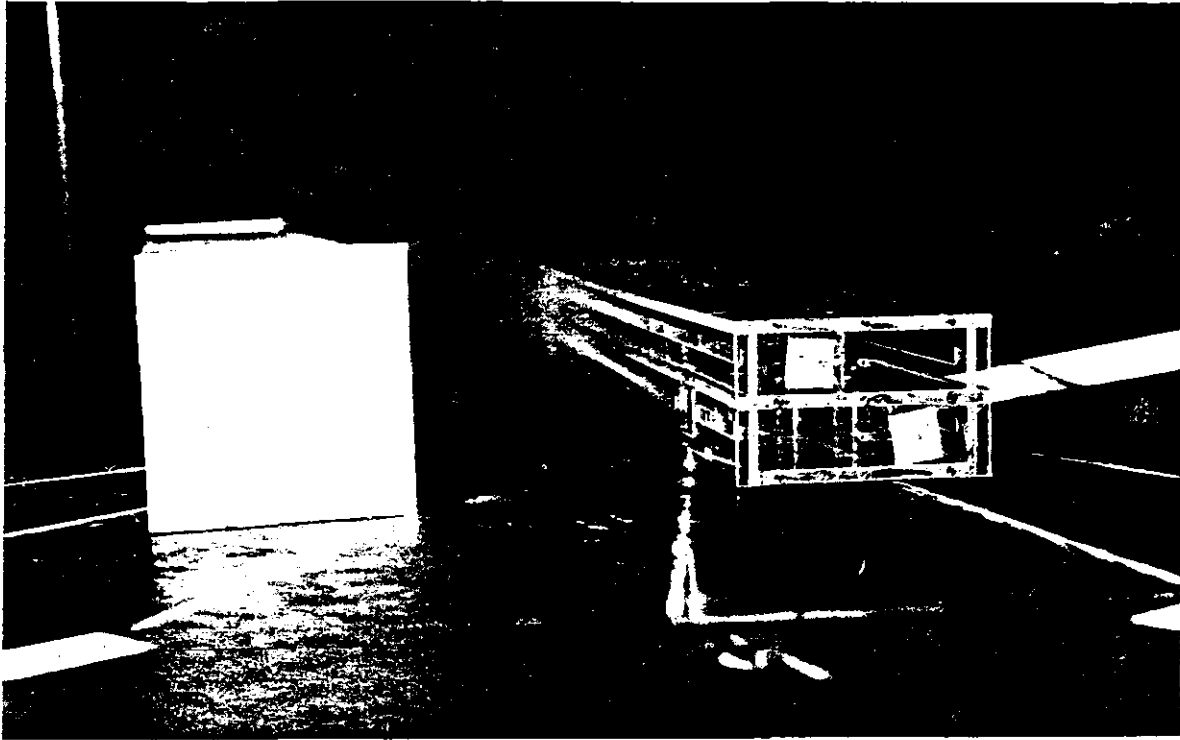

(i) ASHLEY (1984)



(ii) ASHLEY (1984)

Figure 2-7d: Models used in wind tunnel studies from which data were gathered.



(i) ASHLEY (1984)

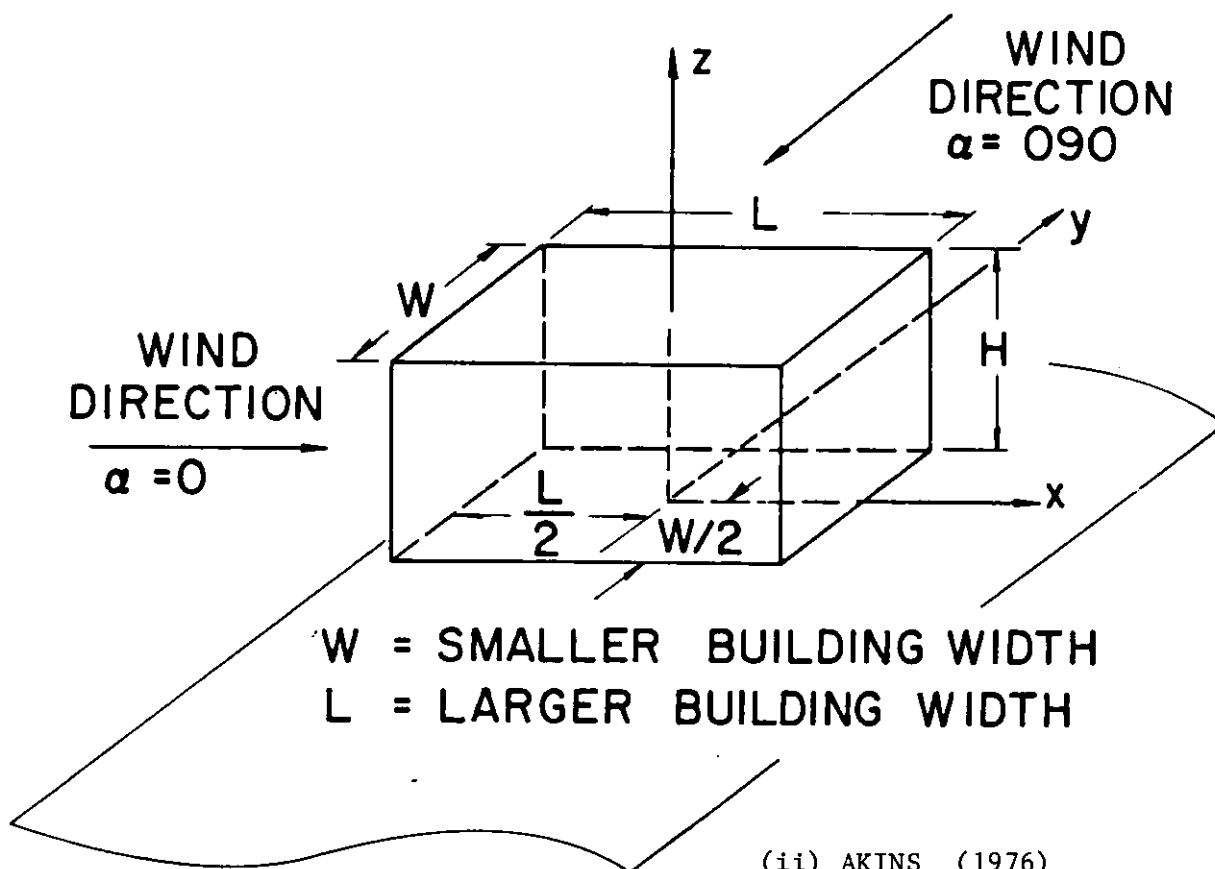

(ii) AKINS (1976)

Figure 2-7e: Models of wind tunnel studies from which data were gathered.

JENSEN (1965) , 2:1:1 , FLAT ROOF , SMALL TURBULENCE

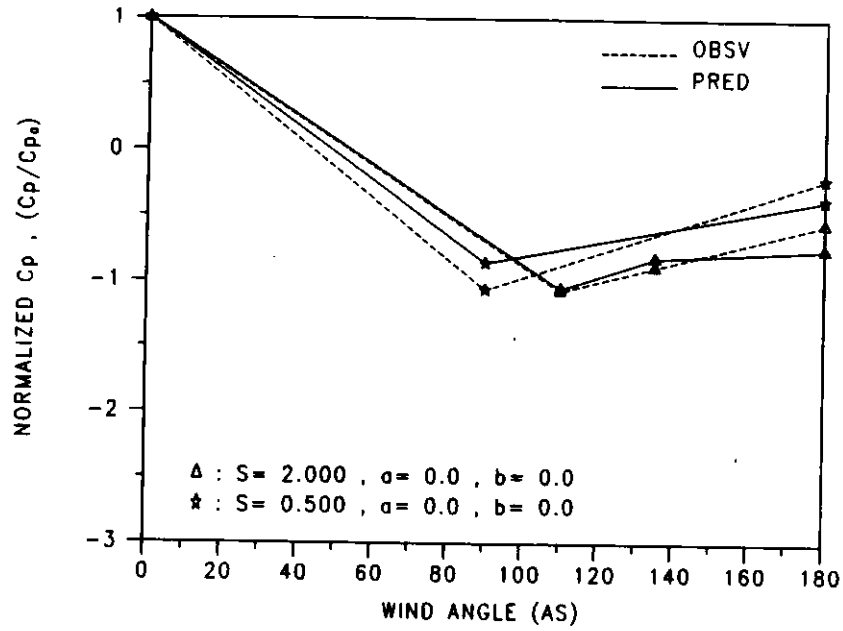

FIGURE 2-8 NORMALIZED PRESS. COEFF. VS WIND ANGLE

JENSEN (1965) , 2:1:1 , FLAT ROOF , LARGE TURBULENCE

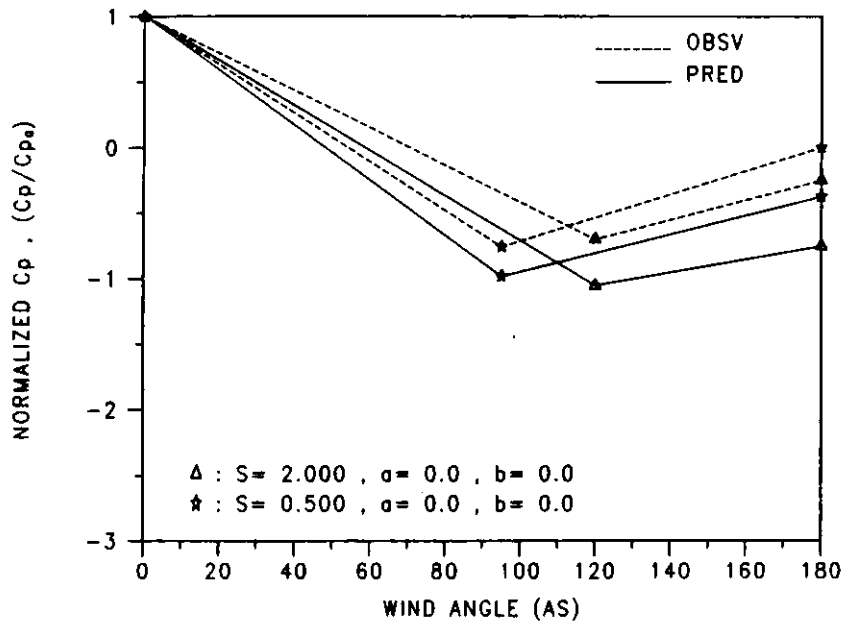

FIGURE 2-9 NORMALIZED PRESS. COEFF. VS WIND ANGLE

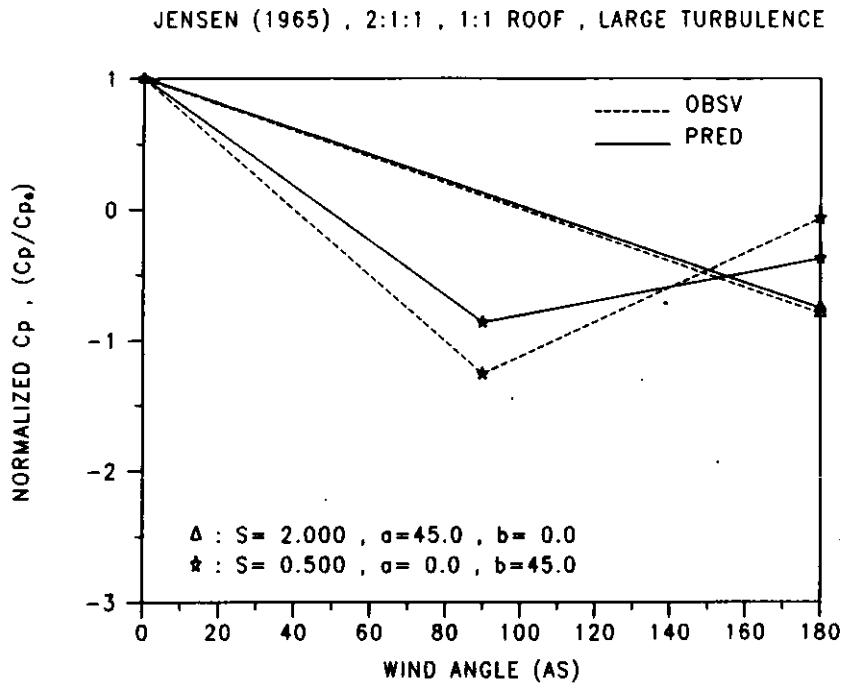

FIGURE 2-10 NORMALIZED PRESS. COEFF. VS WIND ANGLE

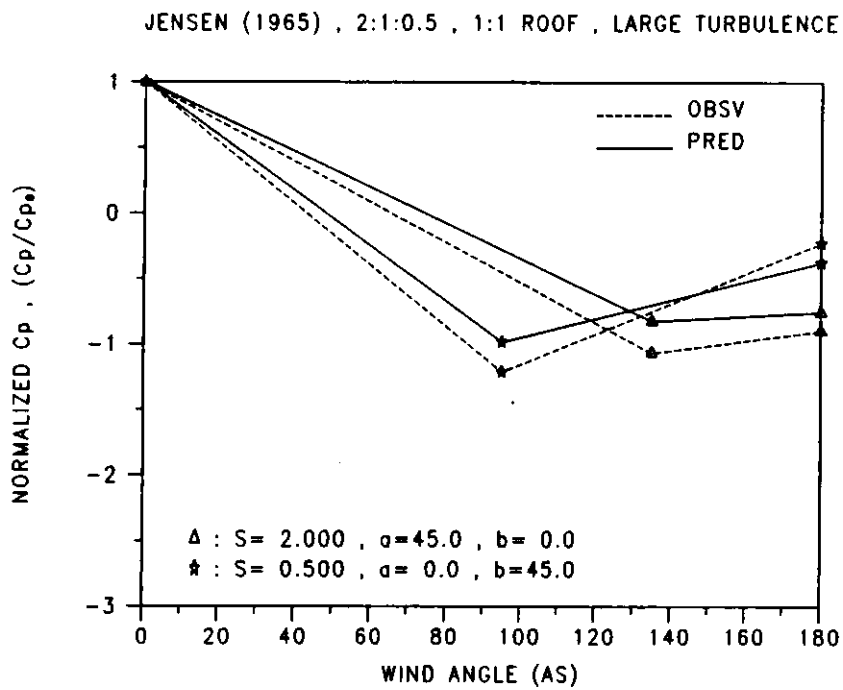

FIGURE 2-11 NORMALIZED PRESS. COEFF. VS WIND ANGLE

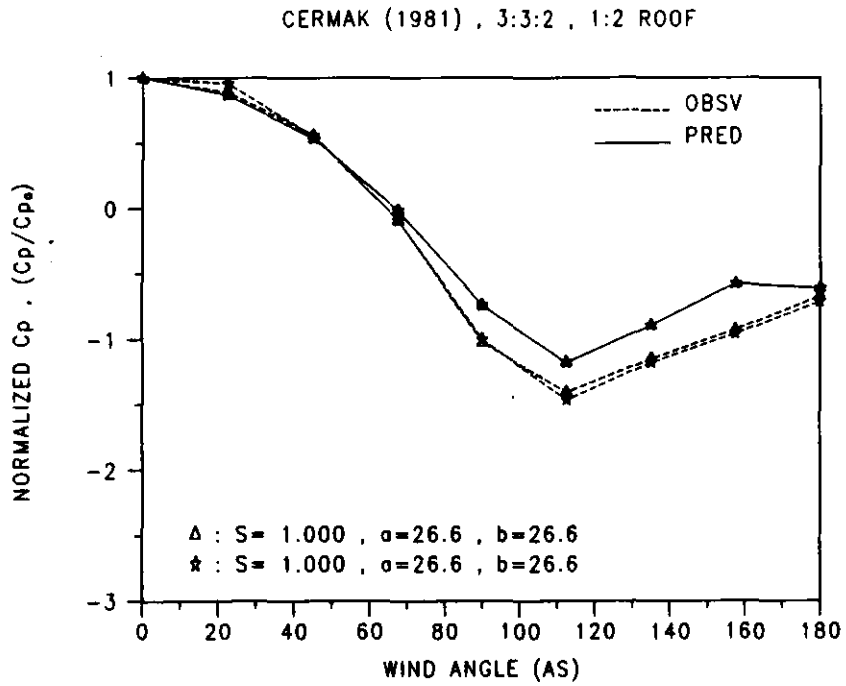

FIGURE 2-12 NORMALIZED PRESS. COEFF. VS WIND ANGLE

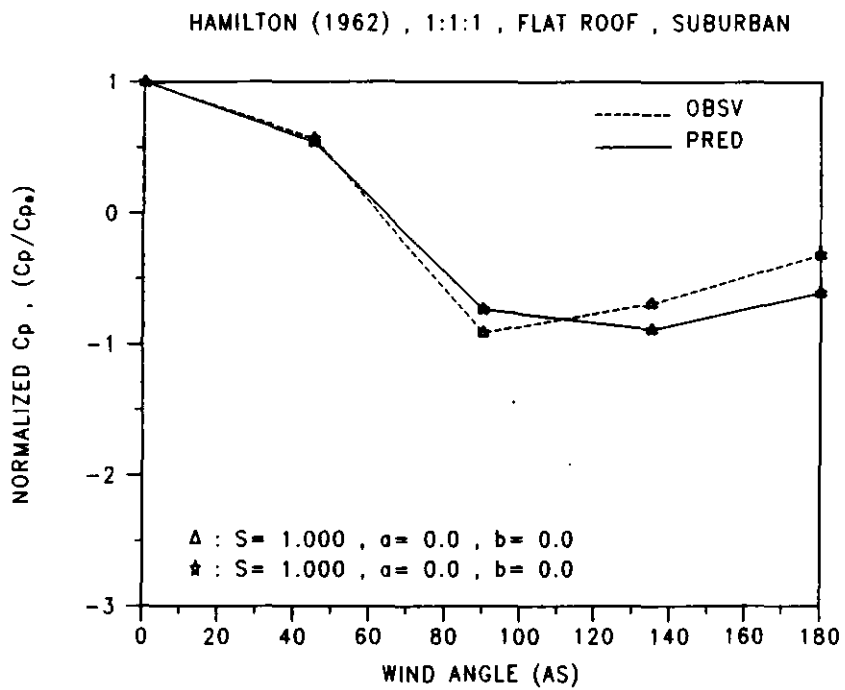

FIGURE 2-13 NORMALIZED PRESS. COEFF. VS WIND ANGLE

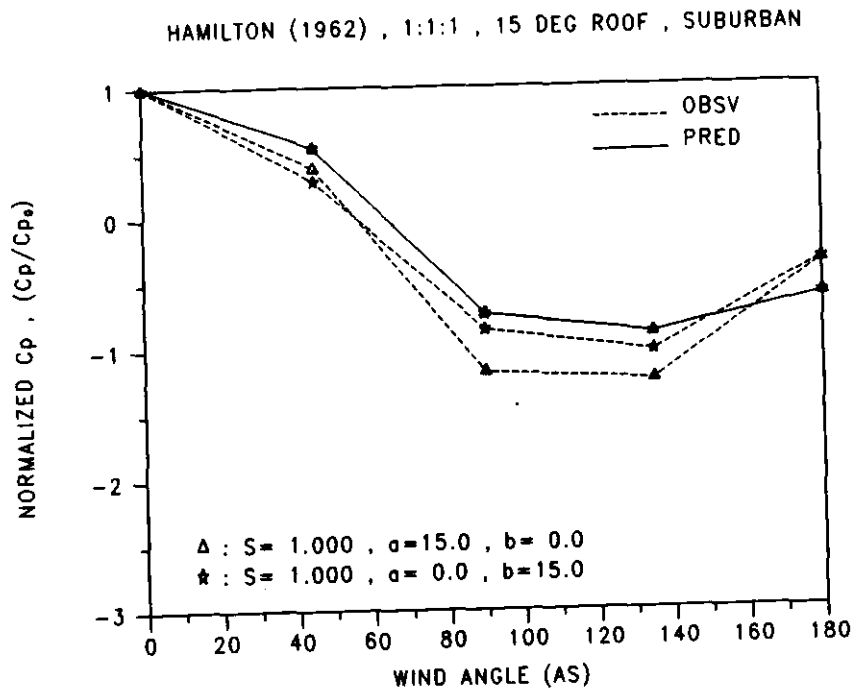

FIGURE 2-14 NORMALIZED PRESS. COEFF. VS WIND ANGLE

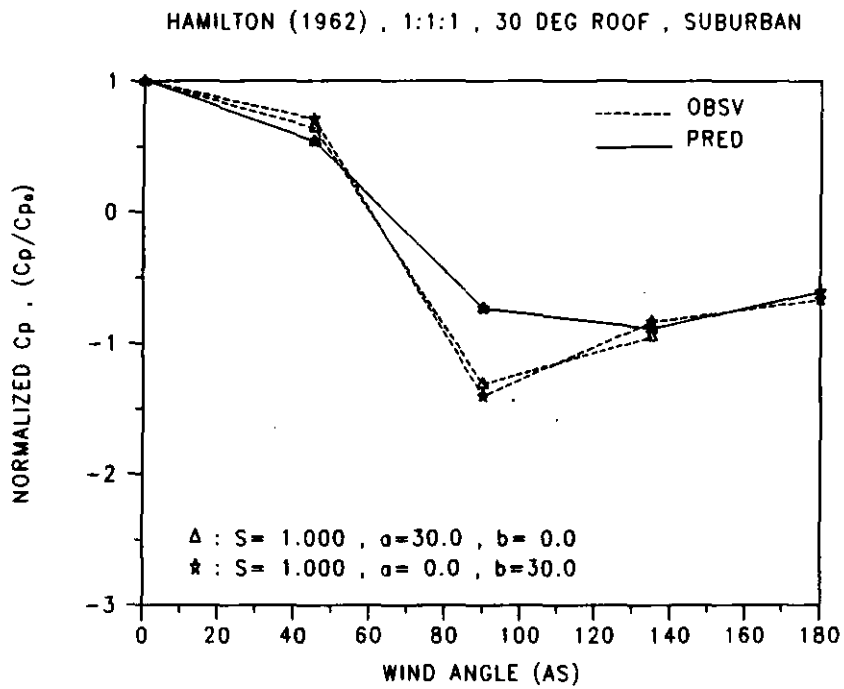

FIGURE 2-15 NORMALIZED PRESS. COEFF. VS WIND ANGLE

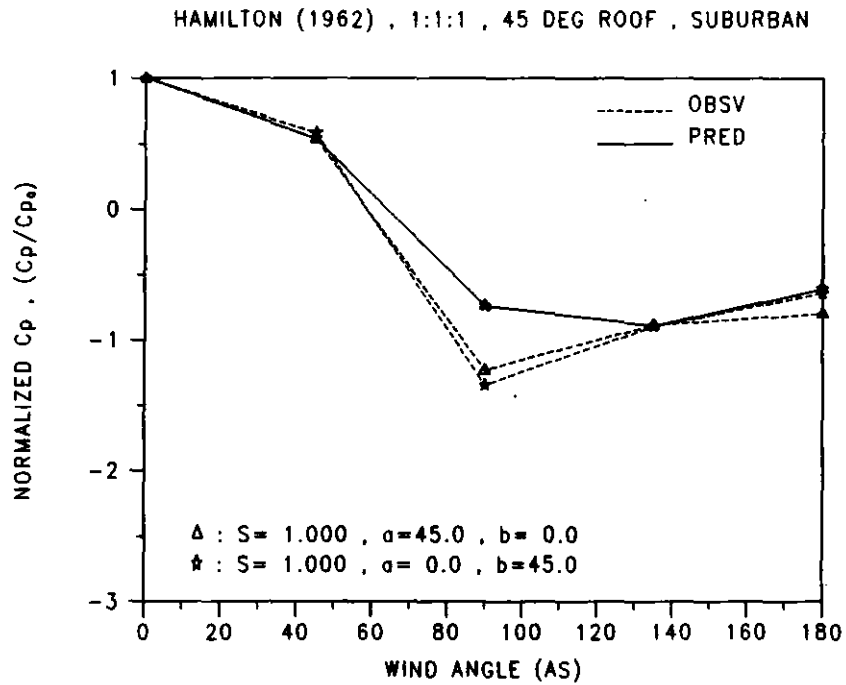

FIGURE 2-16 NORMALIZED PRESS. COEFF. VS WIND ANGLE

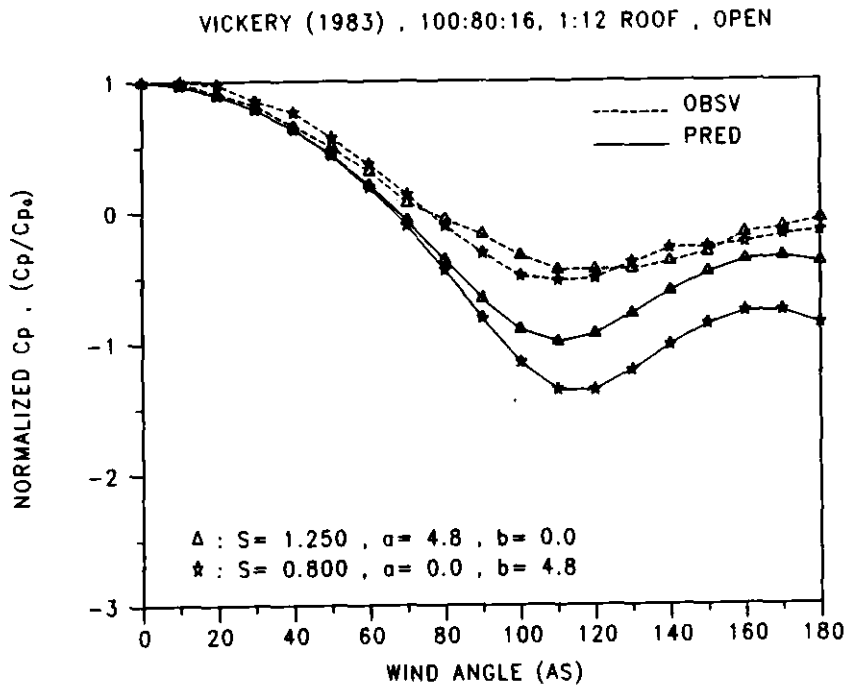

FIGURE 2-17 NORMALIZED PRESS. COEFF. VS WIND ANGLE

VICKERY (1983) , 125:80 , 4:12 ROOF , OPEN

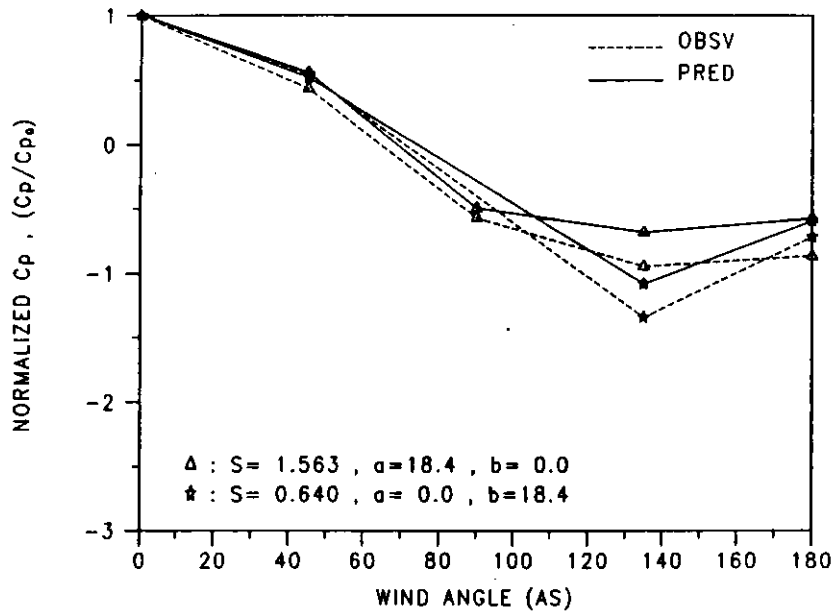

FIGURE 2-18 NORMALIZED PRESS. COEFF. VS WIND ANGLE

VICKERY (1983) , 125:80 , 1:12 ROOF , OPEN

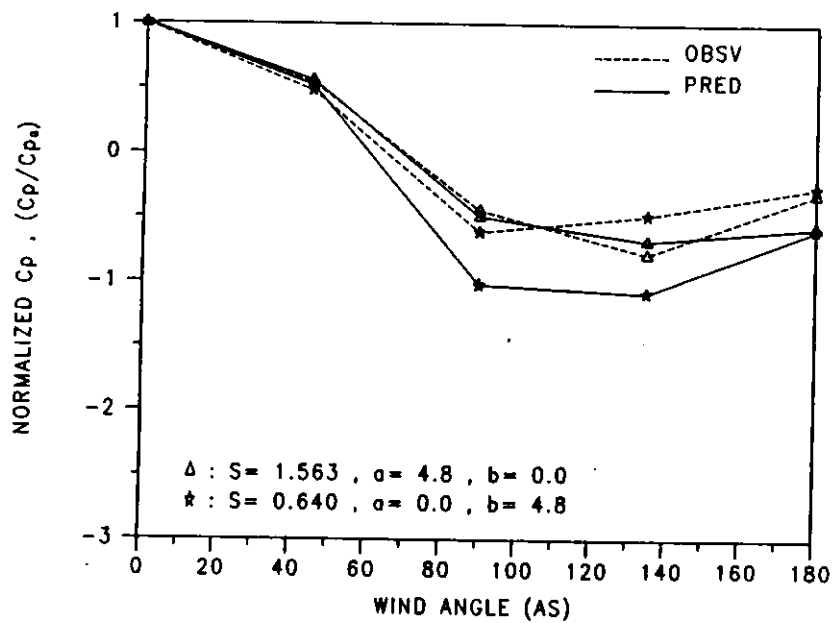

FIGURE 2-19 NORMALIZED PRESS. COEFF. VS WIND ANGLE



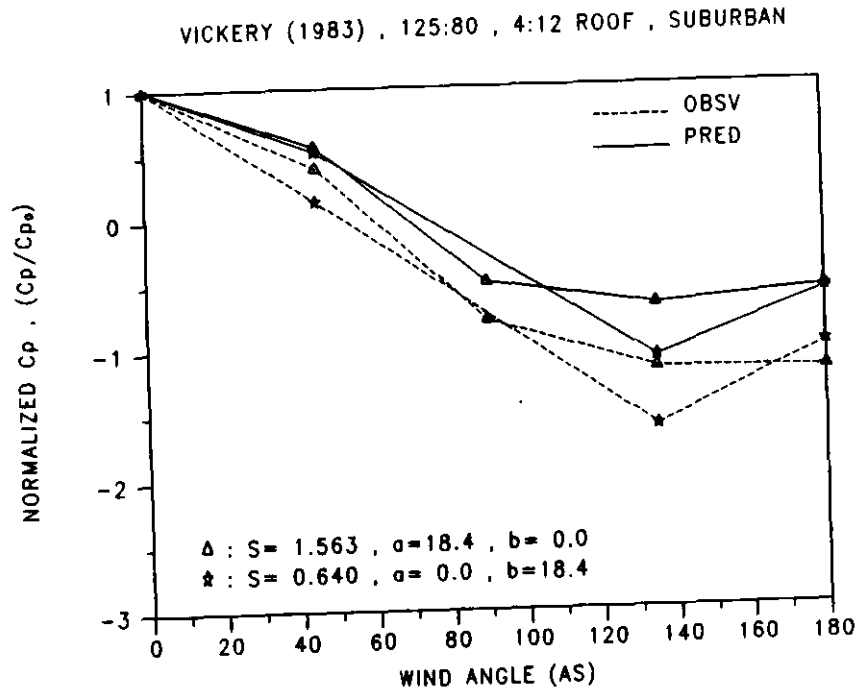

FIGURE 2-20 NORMALIZED PRESS. COEFF. VS WIND ANGLE

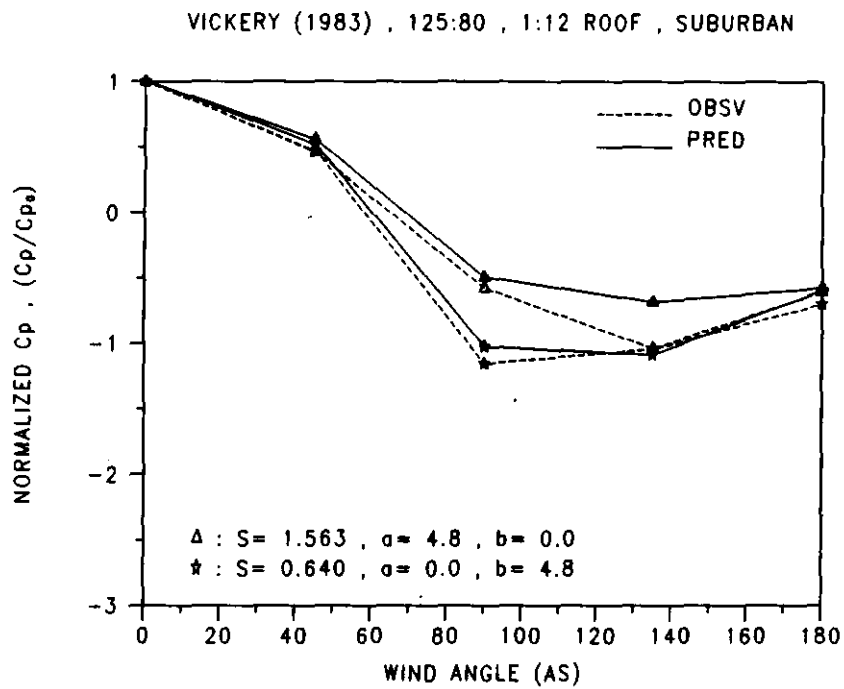

FIGURE 2-21 NORMALIZED PRESS. COEFF. VS WIND ANGLE

WIREN (1983) , 130:85:32 , 45 DEG ROOF , OPEN

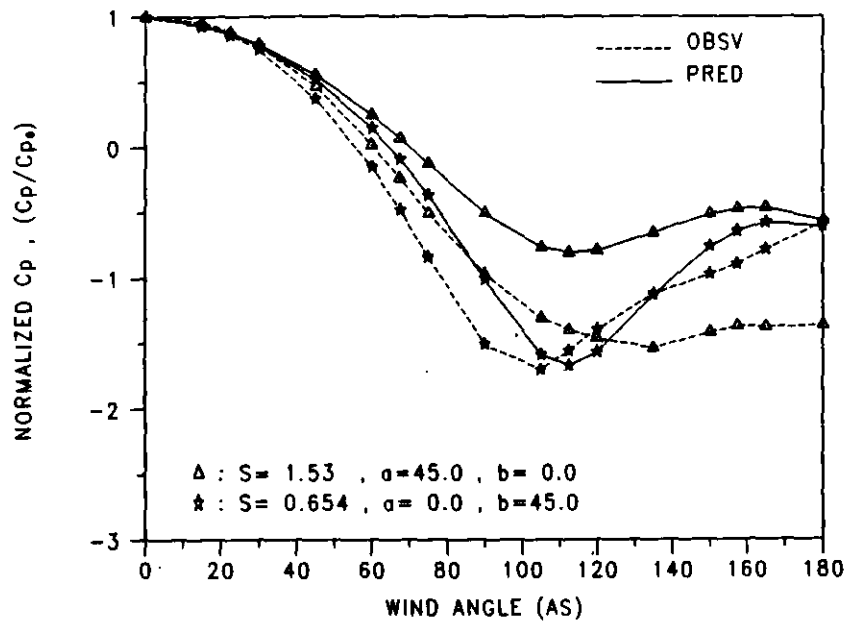

FIGURE 2-22 NORMALIZED PRESS. COEFF. VS WIND ANGLE

LUSCH (1964) , 4:2:1 , FLAT ROOF

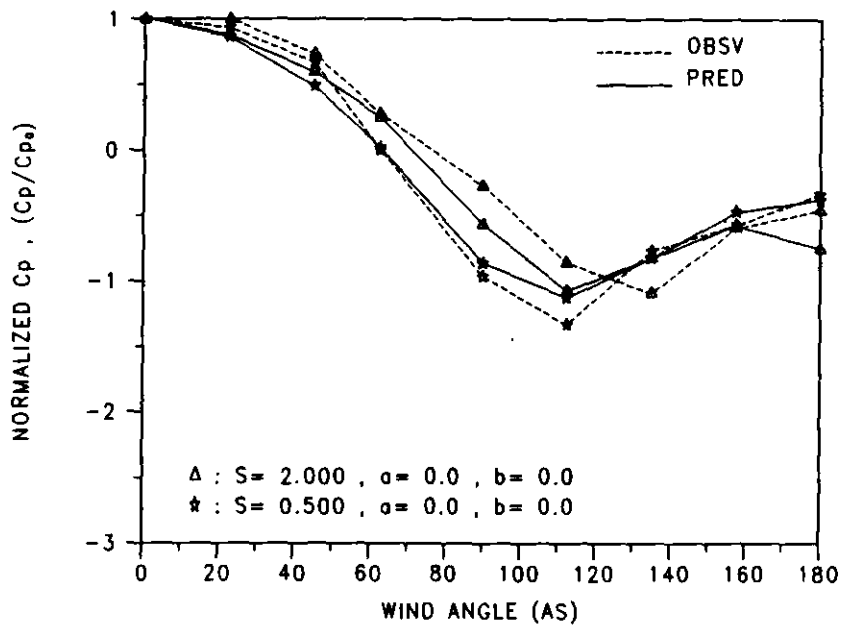

FIGURE 2-23 NORMALIZED PRESS. COEFF. VS WIND ANGLE

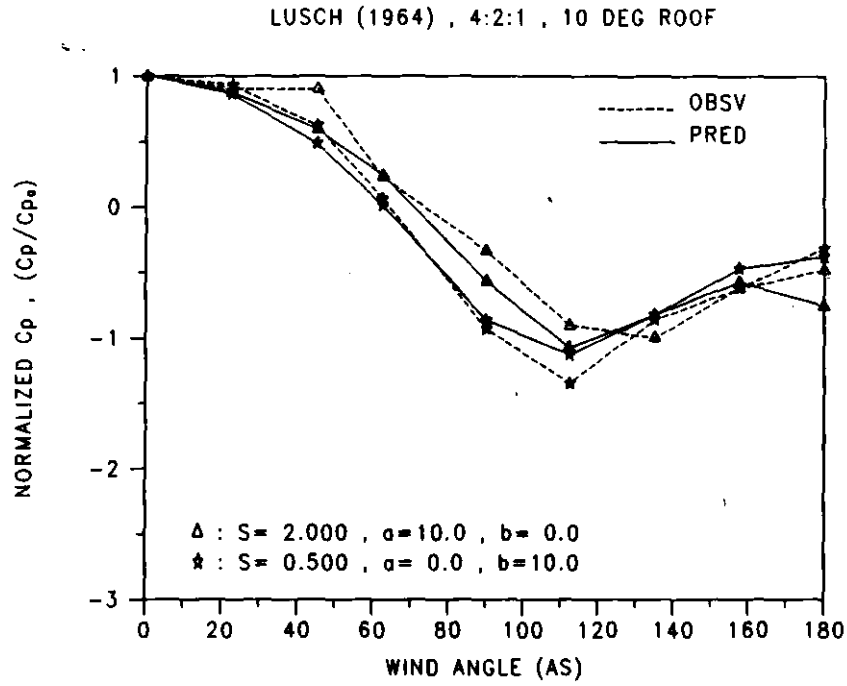

FIGURE 2-24 NORMALIZED PRESS. COEFF. VS WIND ANGLE

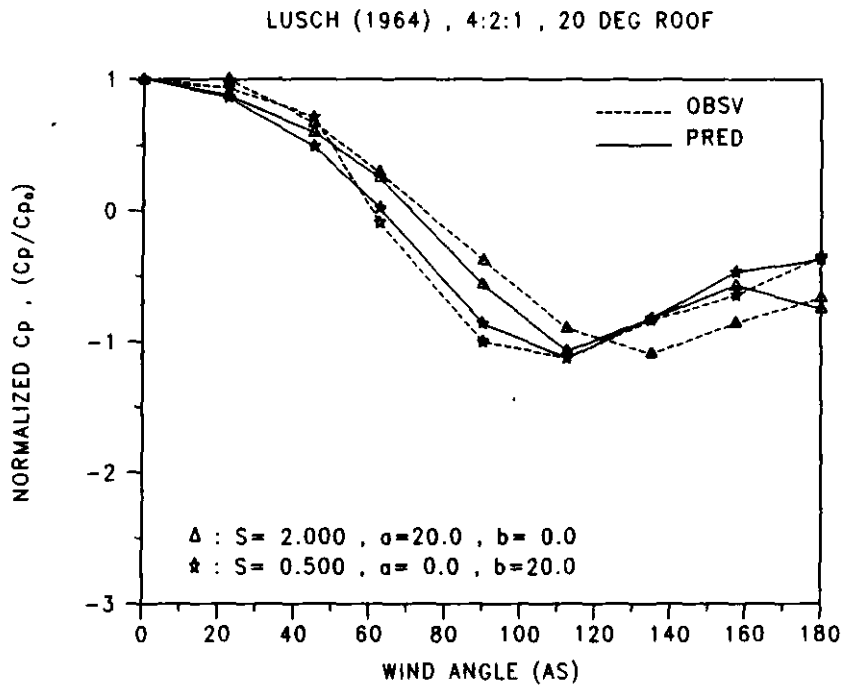

FIGURE 2-25 NORMALIZED PRESS. COEFF. VS WIND ANGLE

LUSCH (1964) , 4:2:1 , 30 DEG ROOF

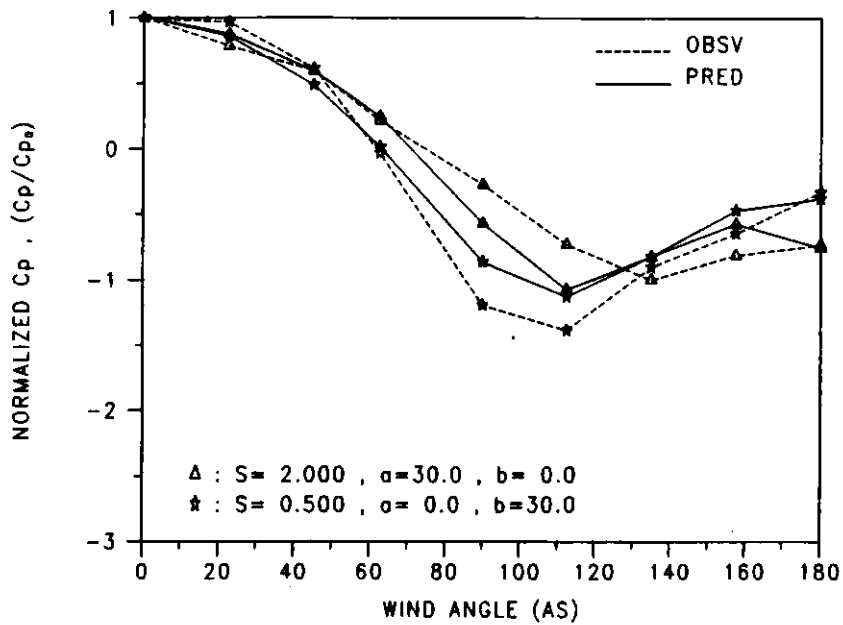

FIGURE 2-26 NORMALIZED PRESS. COEFF. VS WIND ANGLE

LUSCH (1964) , 4:2:1 , 40 DEG ROOF

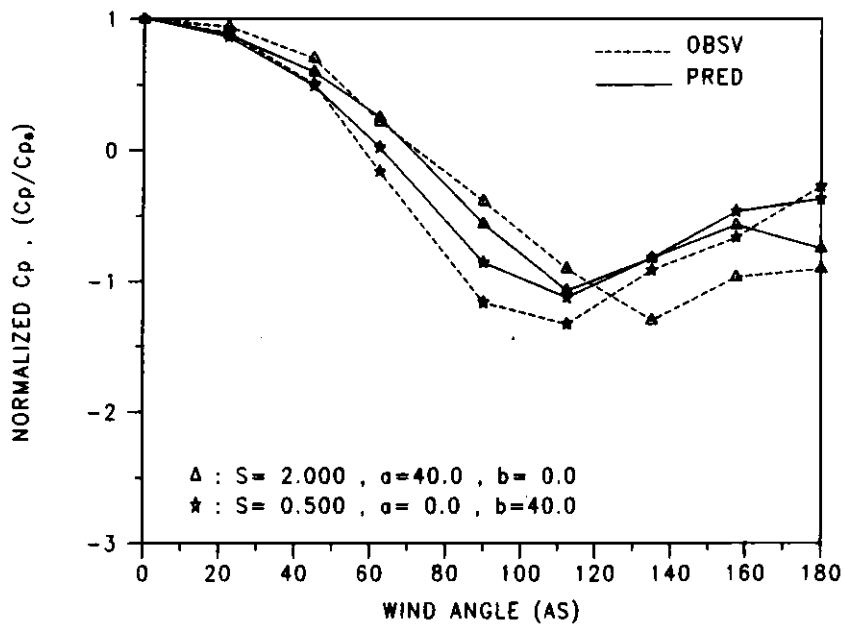

FIGURE 2-27 NORMALIZED PRESS. COEFF. VS WIND ANGLE

LUSCH (1964), 4:2:1, 60 DEG ROOF

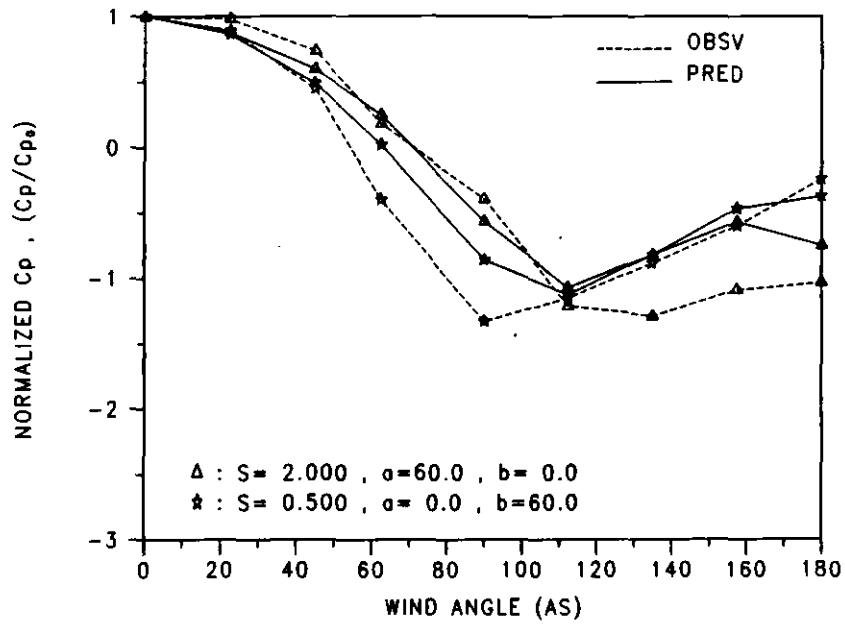

FIGURE 2-28 NORMALIZED PRESS. COEFF. VS WIND ANGLE

ASHLEY (1984), 8:1:0.5, FLAT ROOF, SUBURBAN

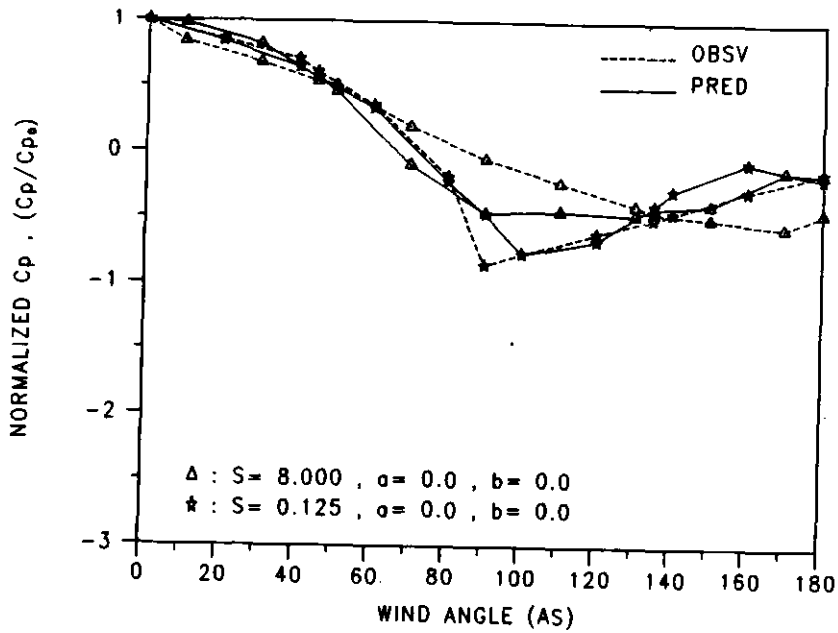

FIGURE 2-29 NORMALIZED PRESS. COEFF. VS WIND ANGLE

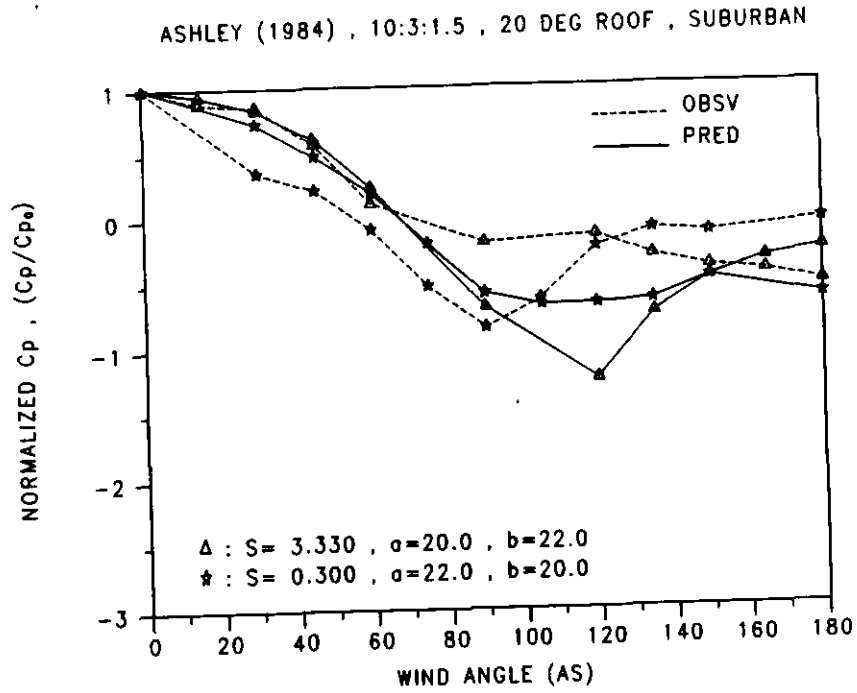

FIGURE 2-30 NORMALIZED PRESS. COEFF. VS WIND ANGLE

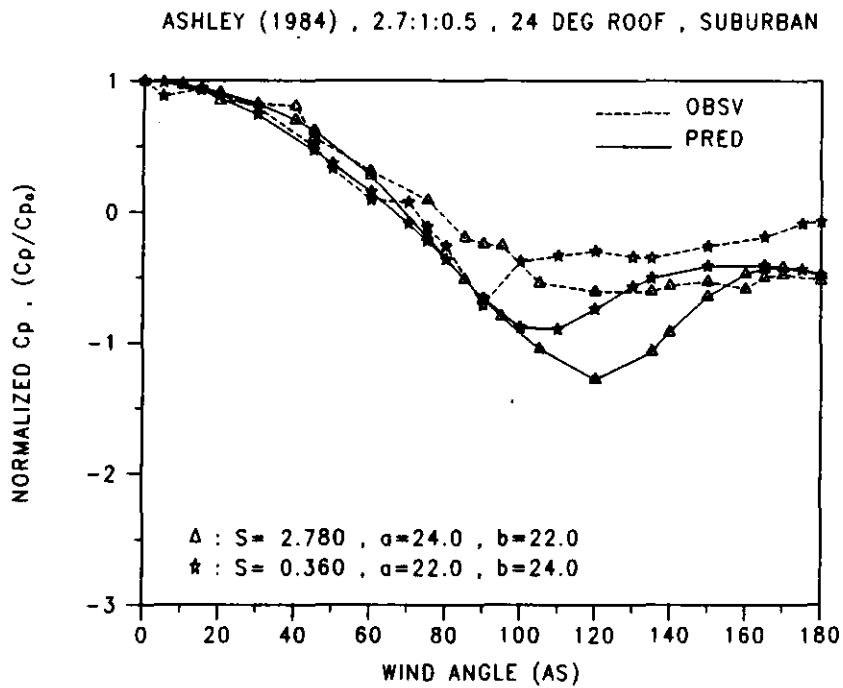

FIGURE 2-31 NORMALIZED PRESS. COEFF. VS WIND ANGLE

AKINS (1979) , 1:1 , FLAT ROOF , SUBURBAN

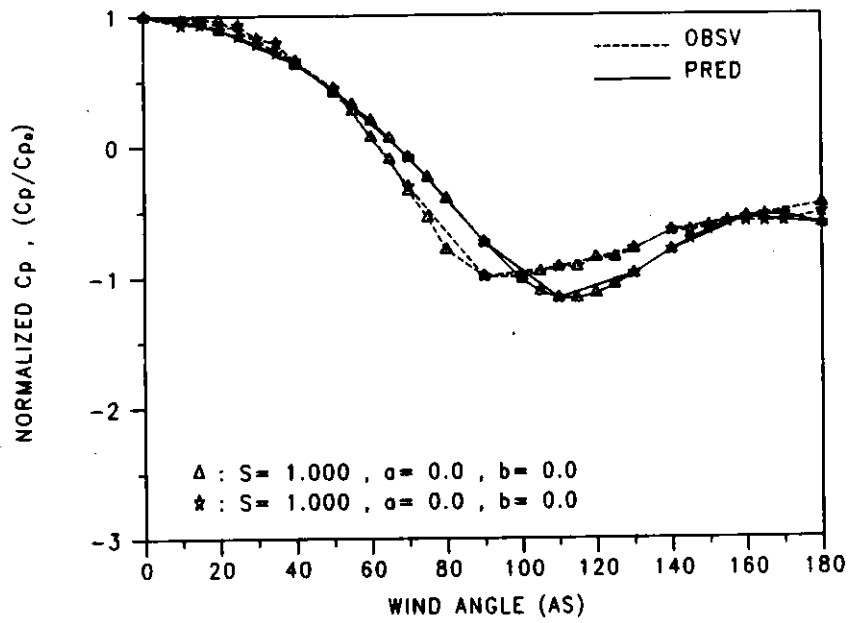

FIGURE 2-32 NORMALIZED PRESS. COEFF. VS WIND ANGLE

AKINS (1979) , 2:1 , FLAT ROOF , SUBURBAN

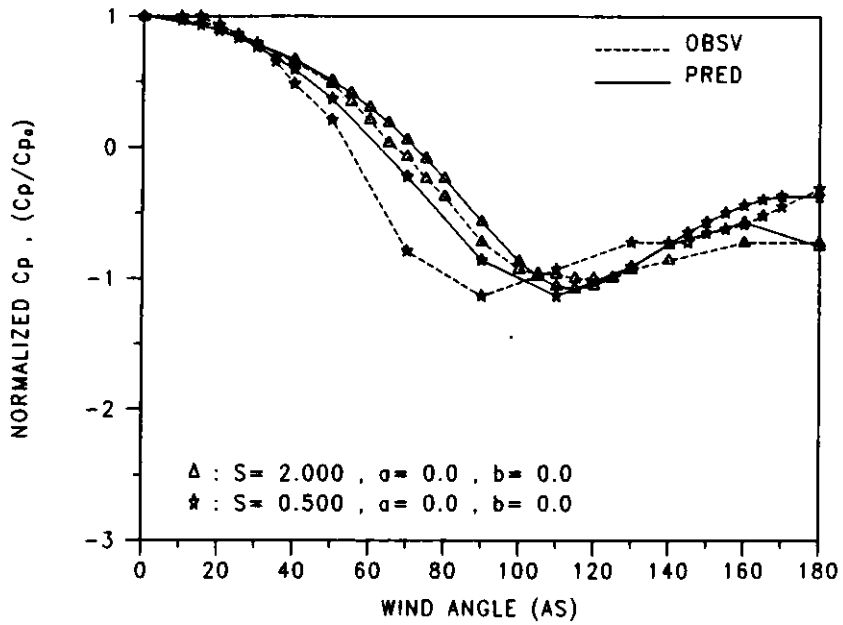

FIGURE 2-33 NORMALIZED PRESS. COEFF. VS WIND ANGLE

AKINS (1979) , 4:1 , FLAT ROOF , SUBURBAN

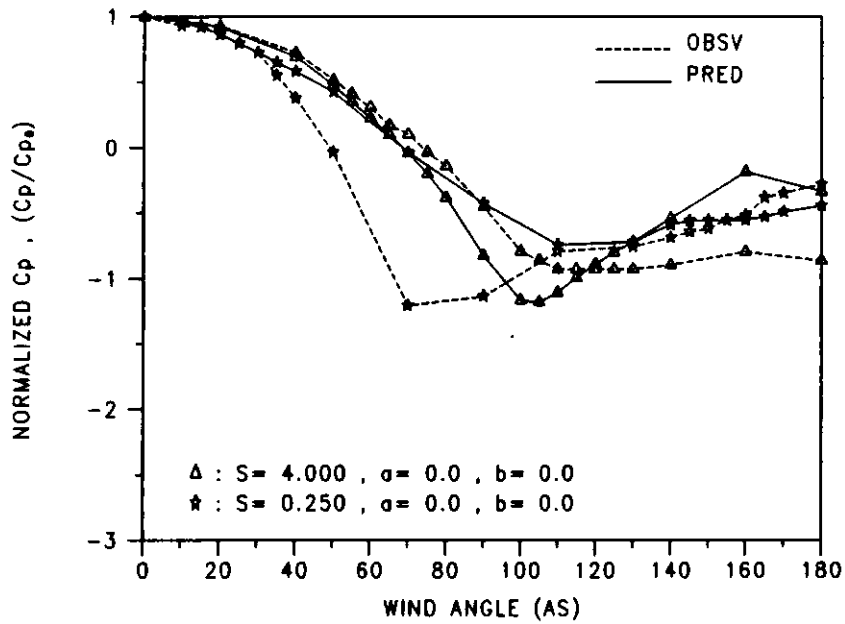

FIGURE 2-34 NORMALIZED PRESS. COEFF. VS WIND ANGLE

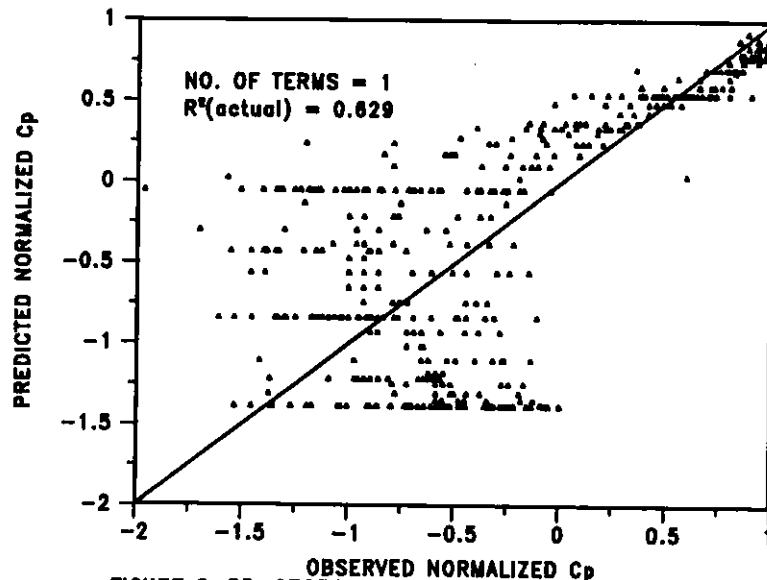

FIGURE 2-35: OBSERVED VS PREDICTED NORMALIZED  $C_p$  FOR DIFFERENT NUMBER OF TERMS IN THE PREDICTION EQUATION



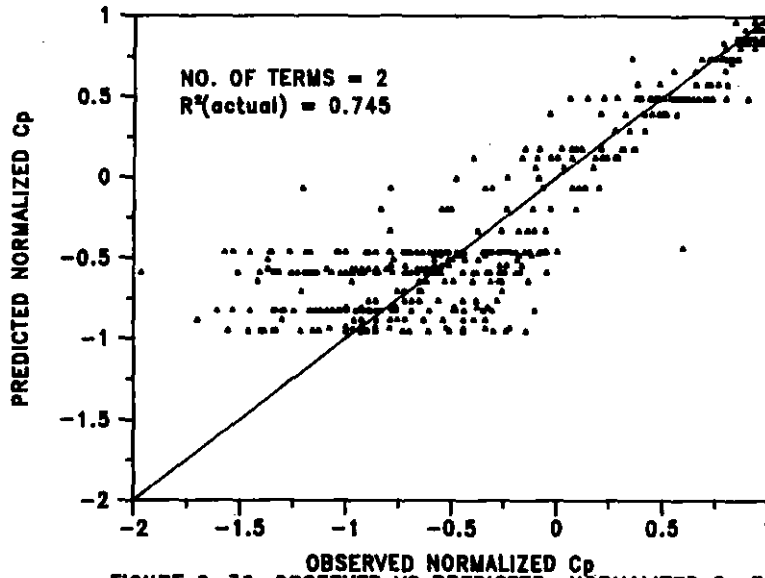

FIGURE 2-36: OBSERVED VS PREDICTED NORMALIZED  $C_p$  FOR DIFFERENT NUMBER OF TERMS IN THE PREDICTION EQUATION

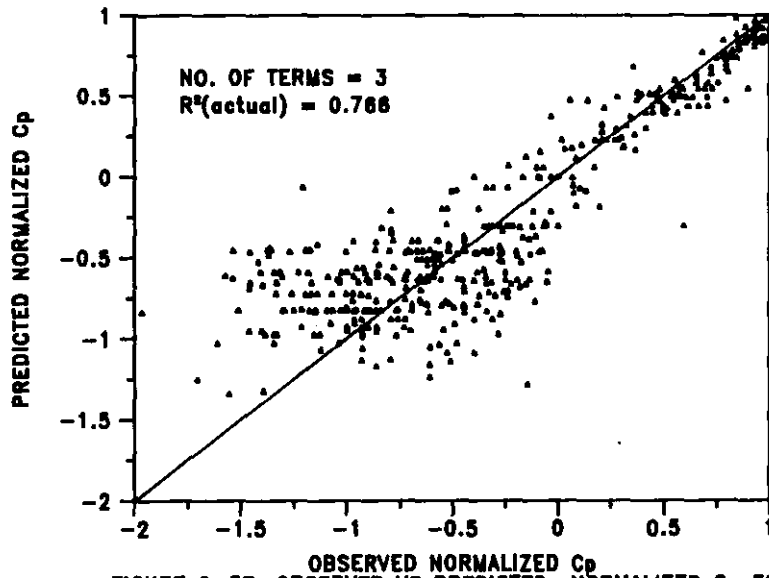

FIGURE 2-37: OBSERVED VS PREDICTED NORMALIZED  $C_p$  FOR DIFFERENT NUMBER OF TERMS IN THE PREDICTION EQUATION

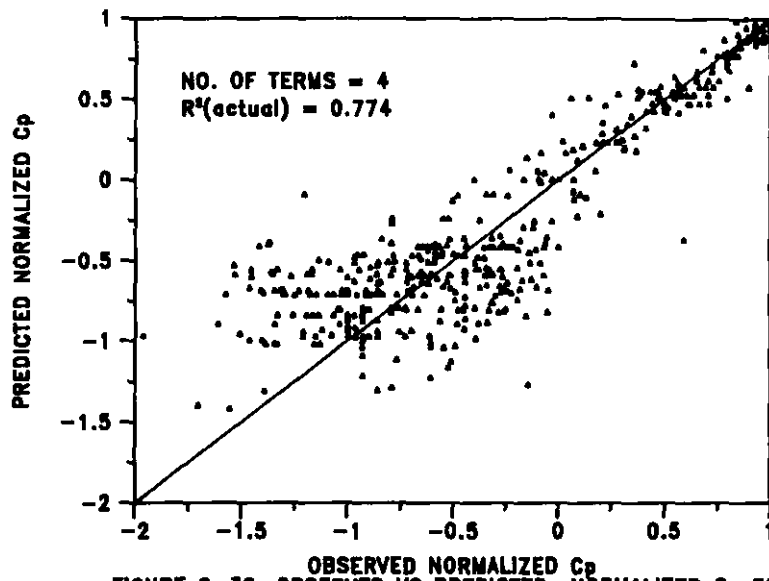

FIGURE 2-38: OBSERVED VS PREDICTED NORMALIZED Cp FOR DIFFERENT NUMBER OF TERMS IN THE PREDICTION EQUATION

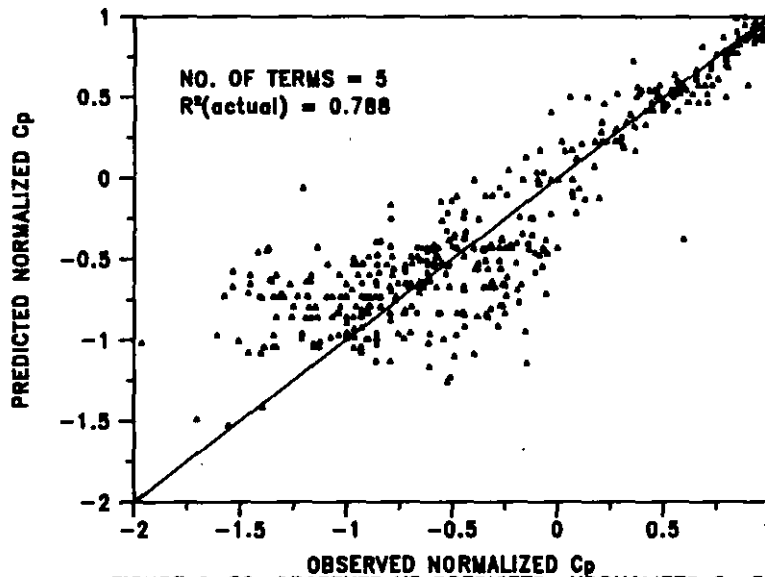

FIGURE 2-39: OBSERVED VS PREDICTED NORMALIZED Cp FOR DIFFERENT NUMBER OF TERMS IN THE PREDICTION EQUATION

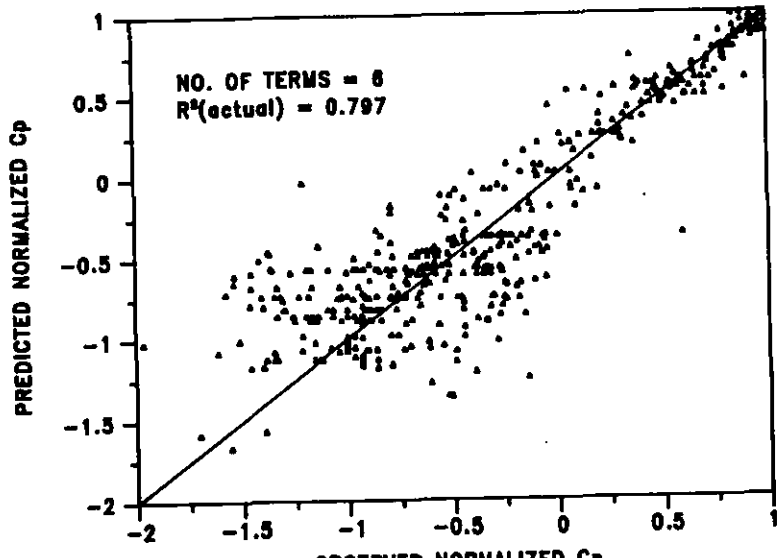

FIGURE 2-40: OBSERVED VS PREDICTED NORMALIZED Cp FOR DIFFERENT NUMBER OF TERMS IN THE PREDICTION EQUATION

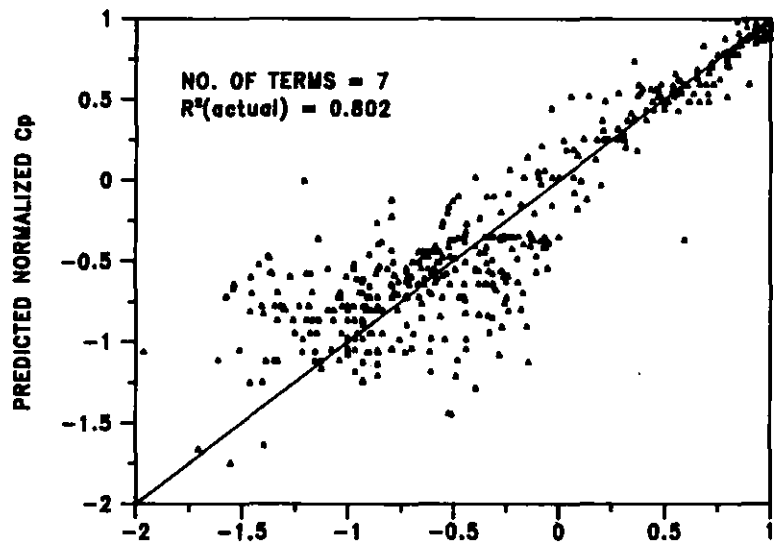

FIGURE 2-41: OBSERVED VS PREDICTED NORMALIZED Cp FOR DIFFERENT NUMBER OF TERMS IN THE PREDICTION EQUATION

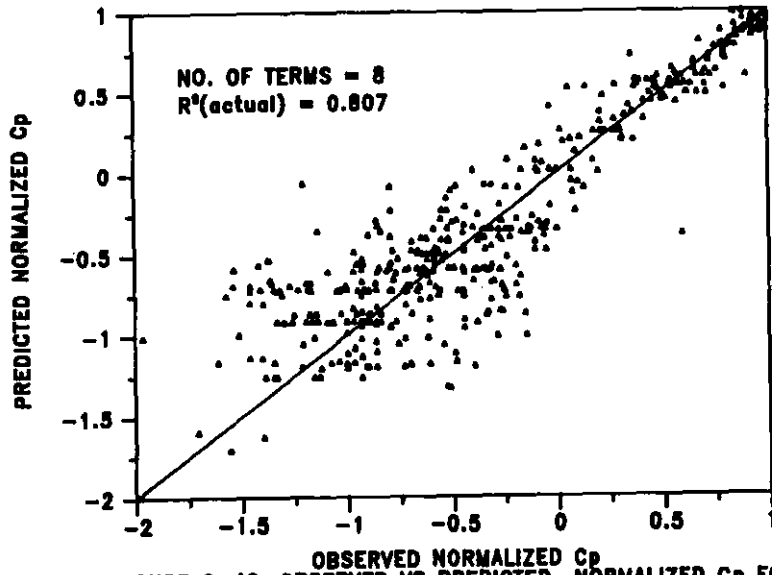

FIGURE 2-42: OBSERVED VS PREDICTED NORMALIZED Cp FOR DIFFERENT NUMBER OF TERMS IN THE PREDICTION EQUATION

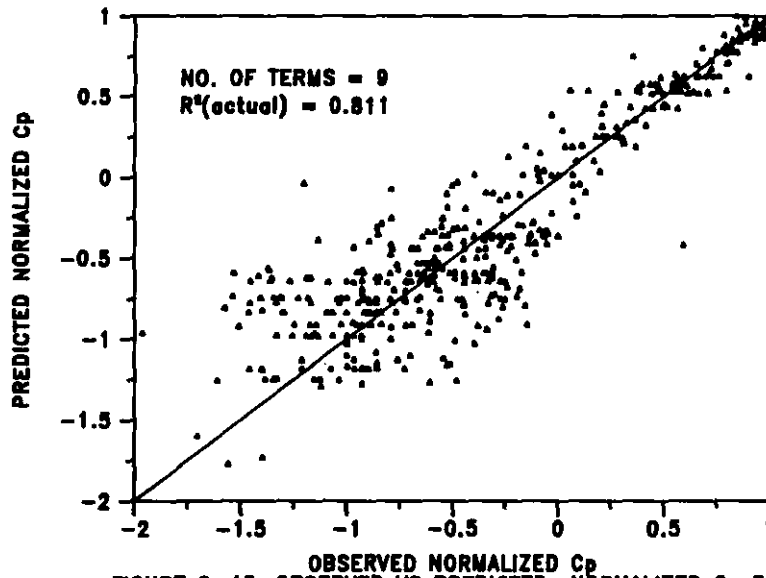

FIGURE 2-43: OBSERVED VS PREDICTED NORMALIZED Cp FOR DIFFERENT NUMBER OF TERMS IN THE PREDICTION EQUATION

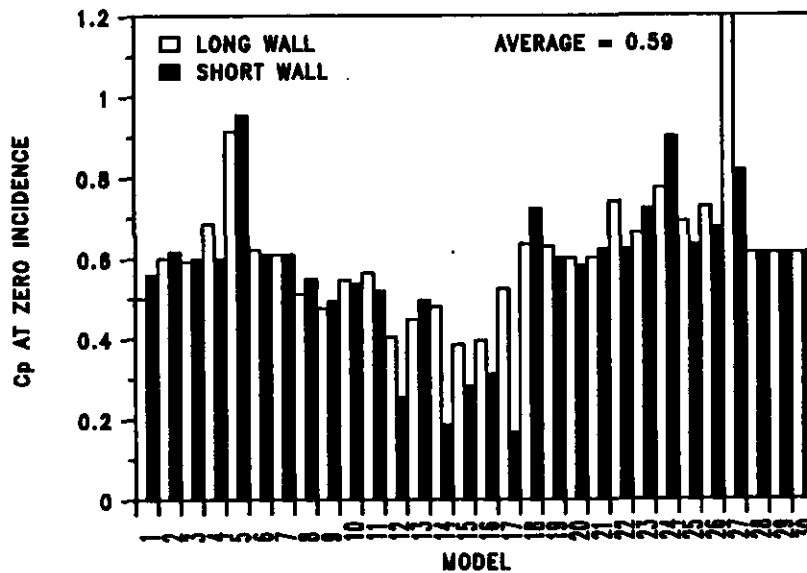
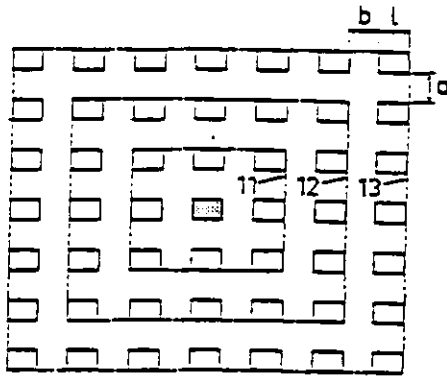

FIGURE 2-44: Cp AT ZERO INCIDENCE FROM VARIOUS MODELS

Source	L:W:H	Model Roof	Terrain
1) JENSEN (1965)	2:1:1	Flatroof,	Open
2) JENSEN (1965)	2:1:1	flatroof,	Industrial
3) JENSEN (1965)	2:1:1	1:1 roof,	Open
4) JENSEN (1965)	2:1:1	1:1 roof,	Industrial
5) JENSEN (1965)	2:1:0.5	1:1 roof,	Industrial
6) CERMAK (1981)	36:36:24	1:2 roof	
7) HAMILTON (1962)	1:1:1	flat roof,	Suburban
8) HAMILTON (1962)	1:1:1	15 deg roof	"
9) HAMILTON (1962)	1:1:1	30 deg roof	"
10) HAMILTON (1962)	1:1:1	45 deg roof	"
11) VICKERY (1983)	100:80	1:12 roof	Open
12) VICKERY (1983)	125:80	4:12 roof	"
13) VICKERY (1983)	125:80	1:12 roof	"
14) VICKERY (1983)	125:80	12:12 roof	"
15) VICKERY (1983)	125:80	4:12 roof	Suburban
16) VICKERY (1983)	125:80	1:12 roof	"
17) VICKERY (1983)	125:80	12:12 roof	"
18) WIREN (1985)	130:85:32	1:1 roof	Open
19) LUSCH (1964)	4:2:1	0 deg roof	Suburban
20) LUSCH (1964)	4:2:1	10 deg roof	"
21) LUSCH (1964)	4:2:1	20 deg roof	"
22) LUSCH (1964)	4:2:1	30 deg roof	"
23) LUSCH (1964)	4:2:1	40 deg roof	"
24) LUSCH (1964)	4:2:1	60 deg roof	"
25) ASHLEY (1984)	8:1:0.5	Flat roof	"
26) ASHLEY (1984)	10:3:1.5	20 deg roof	"
27) ASHLEY (1984)	2.7:1:0.5	24 deg roof	"
28) AKINS (1979)	1:1	Flat roof	"
29) AKINS (1979)	2:1	Flat roof	"
30) AKINS (1979)	4:1	Flat roof	"

Note: Where building height is not specified, the Cp was obtained at by averaging the data from models of same side ratio but different heights.



Config.	a/l = b/l
D11, D12, D13	1
F11, F12, F13	1.5
H11, H12, H13	2

(a) Rectangular Pattern  
From WIREN

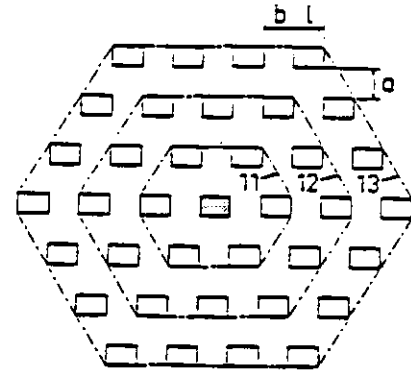

Config.	a/l = b/l
E11, E12, E13	1
G11, G12, G13	1.5
I11, I12, I13	2

(b) Hexagon Arrangement  
From WIREN



Cont:	A00	A10, A20, A30, A40
SF = a/l:	—	1 1.5 2 3
b/l:	—	—

Unobstructed Configuration (c) Single neighboring Building. From WIREN

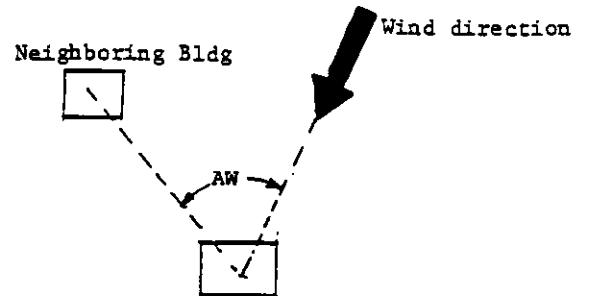

(d) Convention for angle AW

Figure 2-45 Surrounding effects and convention for obstruction angle (AW)

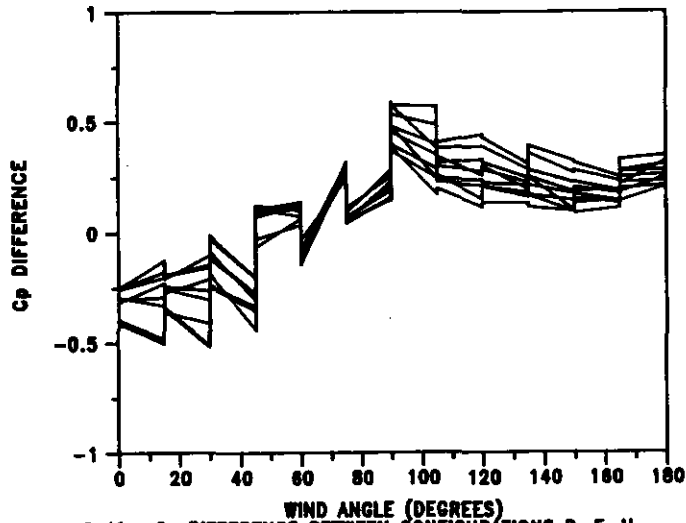

FIG. 2-46:  $C_p$  DIFFERENCE BETWEEN CONFIGURATIONS D, F, H AND UNOBSTRUCTED BUILDING CONFIGURATION (A00).

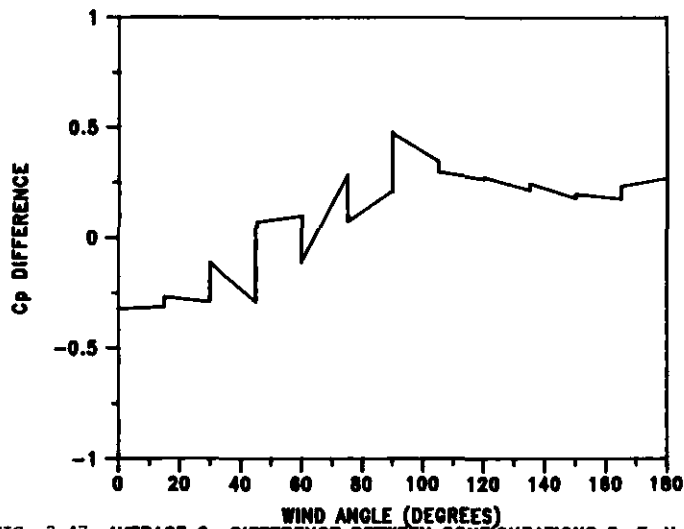

FIG. 2-47: AVERAGE  $C_p$  DIFFERENCE BETWEEN CONFIGURATIONS D, F, H AND UNOBSTRUCTED BUILDING CONFIGURATION (A00).

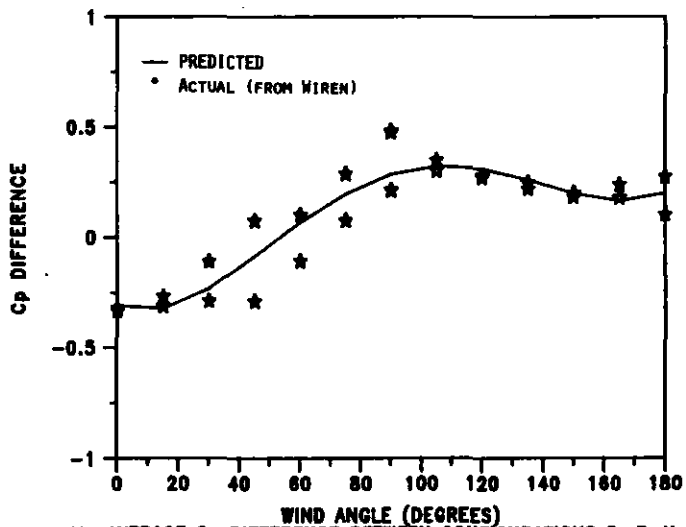

FIG. 2-48: AVERAGE  $C_p$  DIFFERENCE BETWEEN CONFIGURATIONS D, F, H AND UNOBSTRUCTED BUILDING CONFIGURATION (A00).

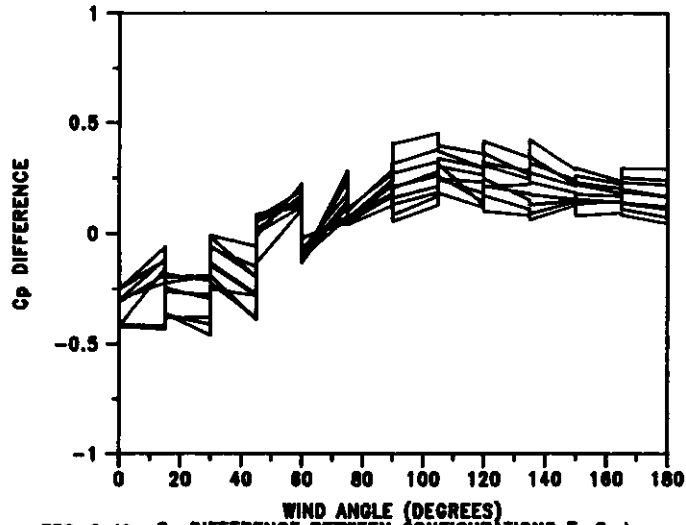

FIG. 2-49: Cp DIFFERENCE BETWEEN CONFIGURATIONS E, G, I AND UNOBSTRUCTED BUILDING CONFIGURATION (A00).

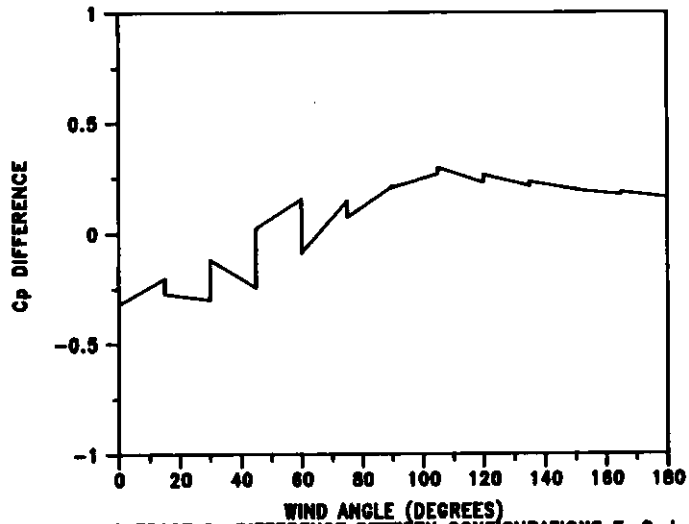

FIG. 2-50: AVERAGE Cp DIFFERENCE BETWEEN CONFIGURATIONS E, G, I AND UNOBSTRUCTED BUILDING CONFIGURATION (A00).

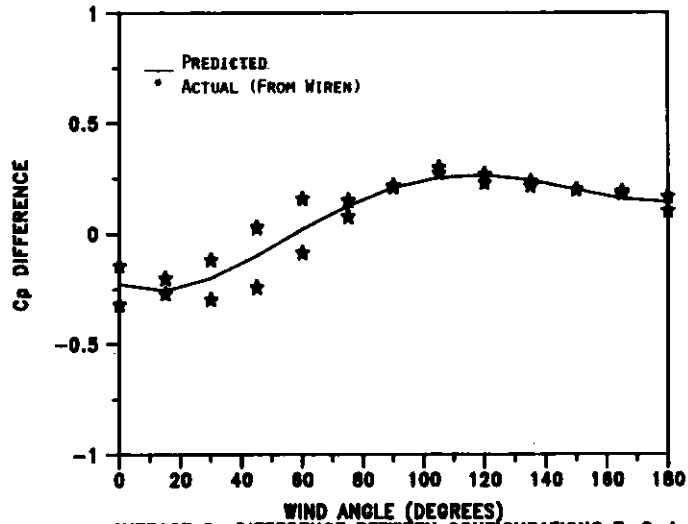

FIG. 2-51: AVERAGE Cp DIFFERENCE BETWEEN CONFIGURATIONS E, G, I AND UNOBSTRUCTED BUILDING CONFIGURATION (A00).



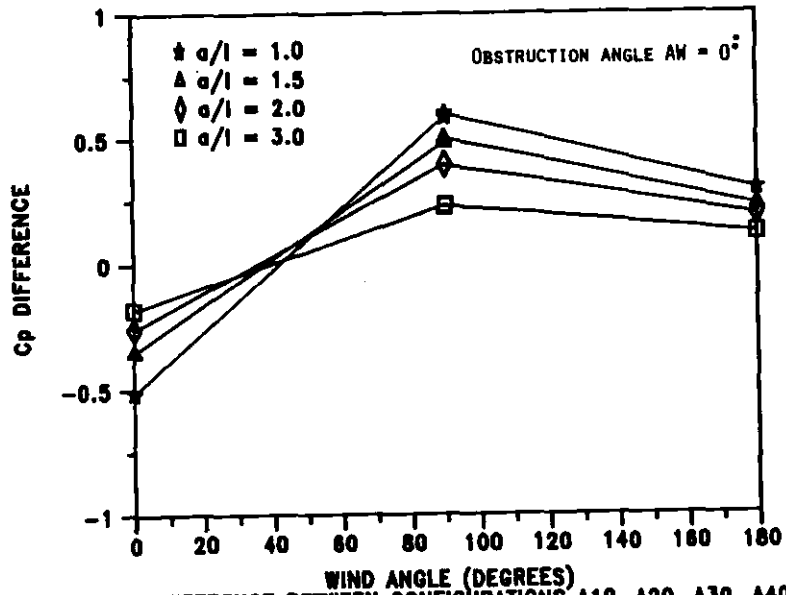

FIG. 2-52:  $C_p$  DIFFERENCE BETWEEN CONFIGURATIONS A10, A20, A30, A40 AND UNOBSTRUCTED BUILDING CONFIGURATION (A00).

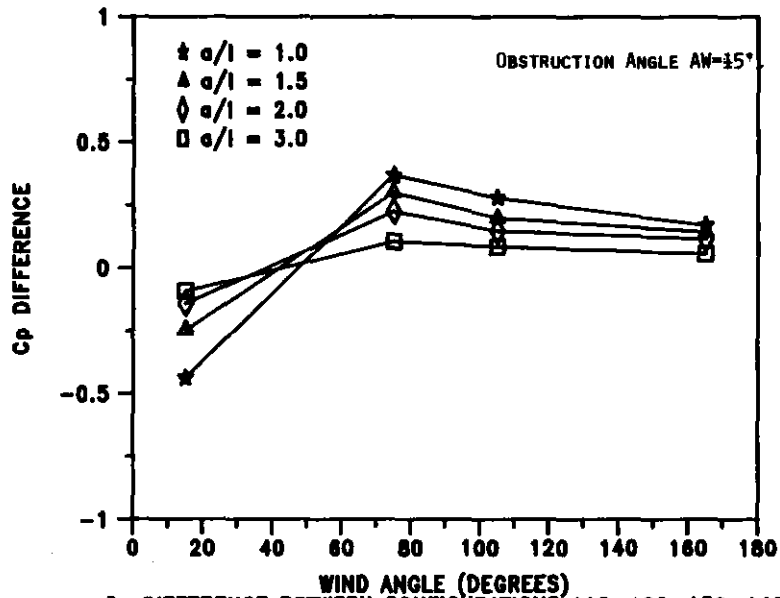

FIG. 2-53:  $C_p$  DIFFERENCE BETWEEN CONFIGURATIONS A10, A20, A30, A40 AND UNOBSTRUCTED BUILDING CONFIGURATION (A00).

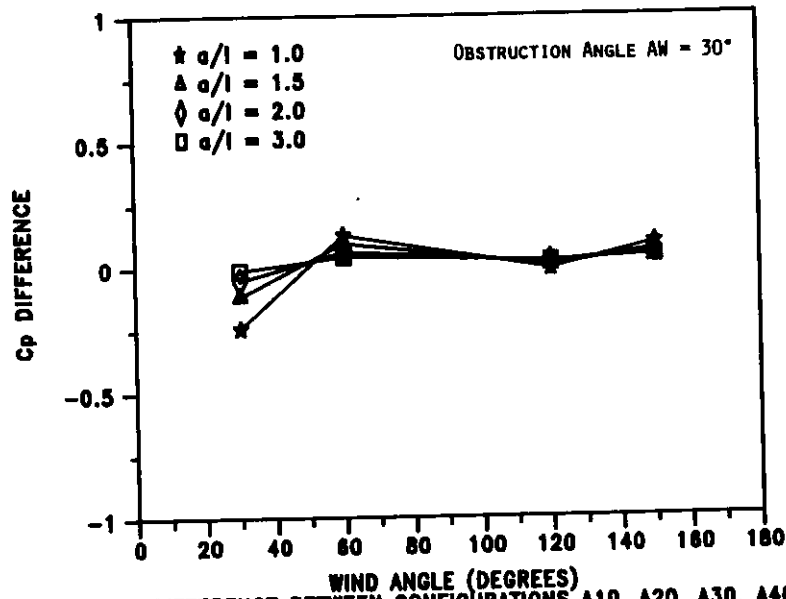

FIG. 2-54:  $C_p$  DIFFERENCE BETWEEN CONFIGURATIONS A10, A20, A30, A40 AND UNOBSTRUCTED BUILDING CONFIGURATION (A00).

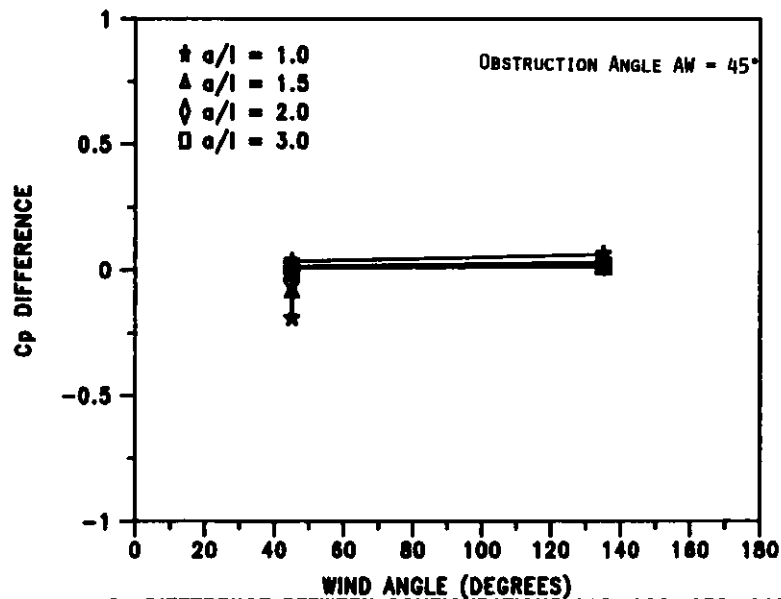

FIG. 2-55:  $C_p$  DIFFERENCE BETWEEN CONFIGURATIONS A10, A20, A30, A40 AND UNOBSTRUCTED BUILDING CONFIGURATION (A00).

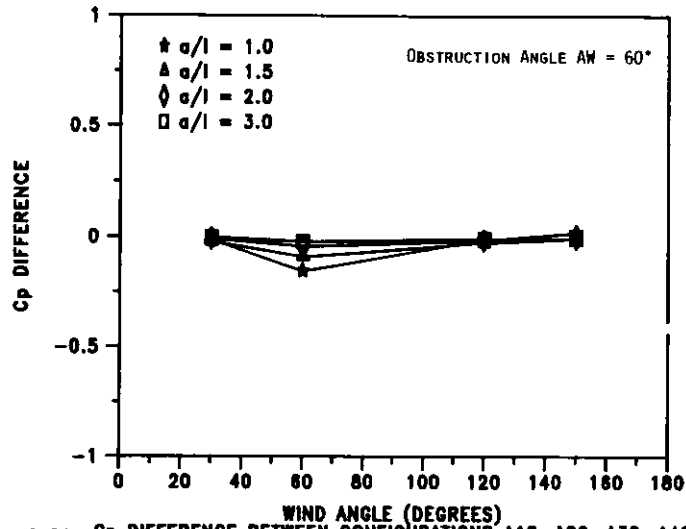

FIG. 2-56:  $C_p$  DIFFERENCE BETWEEN CONFIGURATIONS A10, A20, A30, A40 AND UNOBSTRUCTED BUILDING CONFIGURATION (A00).

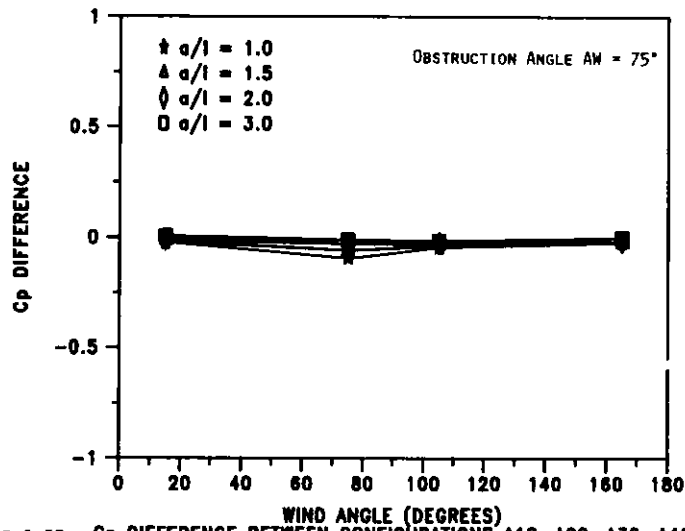

FIG. 2-57:  $C_p$  DIFFERENCE BETWEEN CONFIGURATIONS A10, A20, A30, A40 AND UNOBSTRUCTED BUILDING CONFIGURATION (A00).

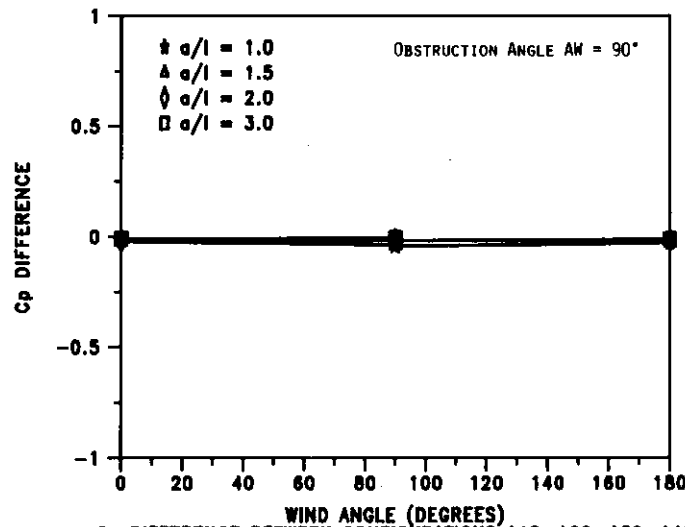
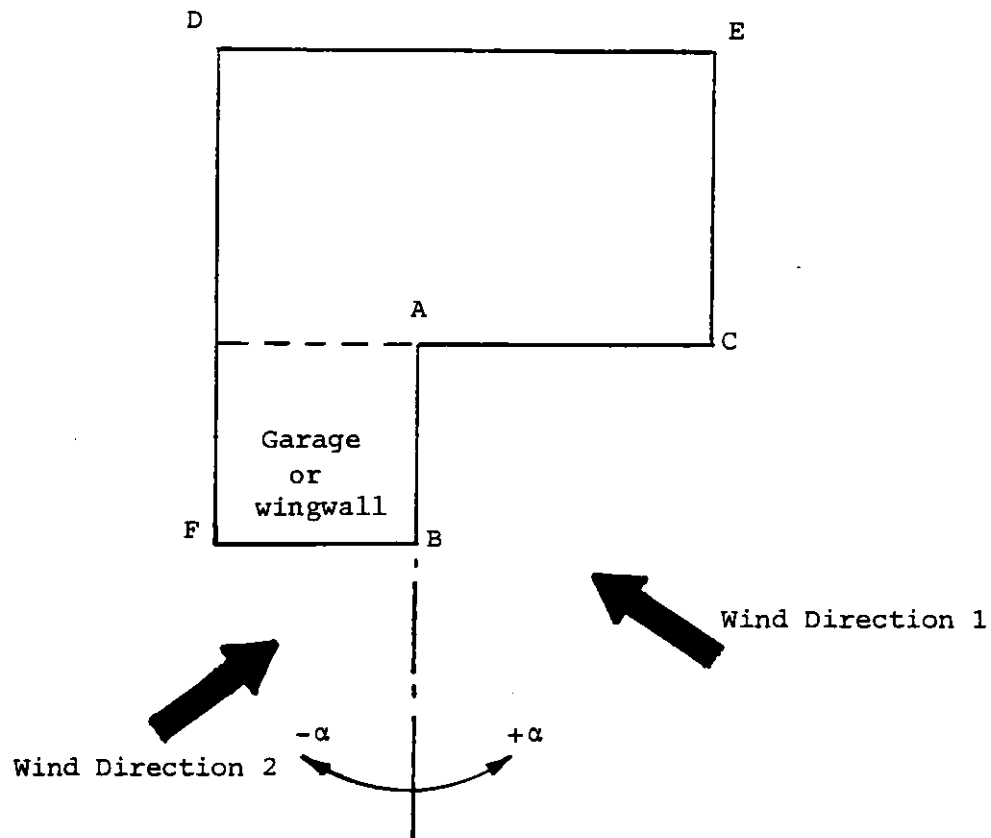

FIG. 2-58:  $C_p$  DIFFERENCE BETWEEN CONFIGURATIONS A10, A20, A30, A40 AND UNOBSTRUCTED BUILDING CONFIGURATION (A00).



The correction/modification for wall AC should be as follows :

- i. For  $\alpha$  in the positive direction up to  $90^\circ$ ,  $C_p$  may be taken as the value at 0 incidence (i.e  $C_p=0.6$ )
- ii. For  $\alpha$  in the positive direction greater than  $90^\circ$ , no correction is suggested.
- iii. For  $\alpha$  in the negative direction and up to  $-90^\circ$ , include the apertures in wall AC as if they are in Wall EC and use normal equations.

Figure 2-59 Correction/Modification to  $C_p$  for the Presence of Garage or Wingwalls

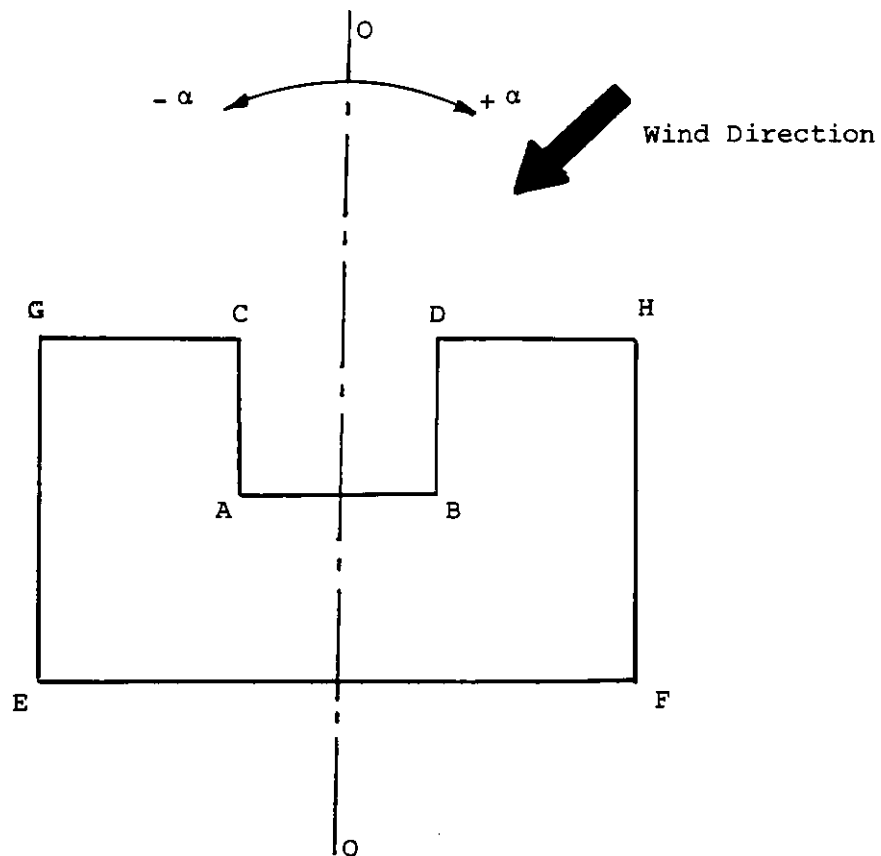

The following modification to  $C_p$ s for walls AB, AC and BD is suggested as follows :

- i. For angles  $\alpha$  up to  $\pm 45^\circ$ ,  $C_p$  for all walls AB, AC and BD may be assumed to be the value at zero incidence (i.e.  $C_p = 0.6$ ) .
- ii. For positive  $\alpha$  up to  $60^\circ$ , walls AB and AC may be taken to be at zero incidence (i.e.  $C_p=0.6$ ). Window(s) in wall BD may be added to those in wall EF .
- iii. For negative angle  $\alpha$  up to  $60^\circ$ . walls DB and AB may be taken to be at 0 incidence (i.e.  $C_p=0.6$ ). Window(s) in AC may be added to those in wall EF .
- iv. For angle  $\alpha$  beyond  $\pm 60^\circ$ , the apertures in all three walls should be treated as if they are in leeward region. Thus, add all the aperture areas in walls AC, AB and BD and include them as areas in wall GE for  $\alpha > + 60^\circ$ , and in wall HF for  $\alpha < - 60^\circ$ .

Figure 2-60 Modification to  $C_p$  for U-Shaped Building

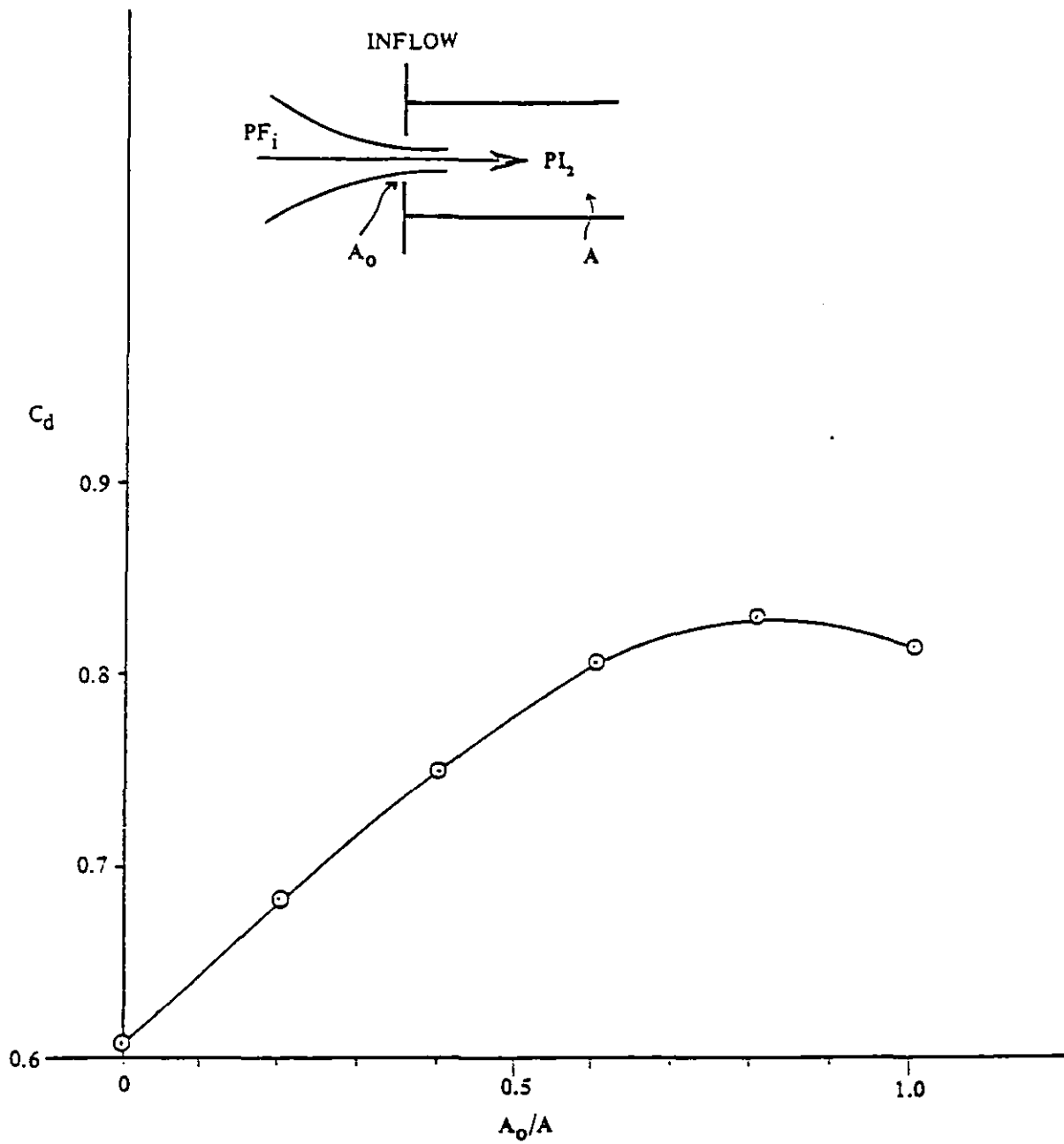

Figure 2-61 DISCHARGE COEFFICIENTS FOR HIGH REYNOLD NUMBER FLOW (From VICKERY)

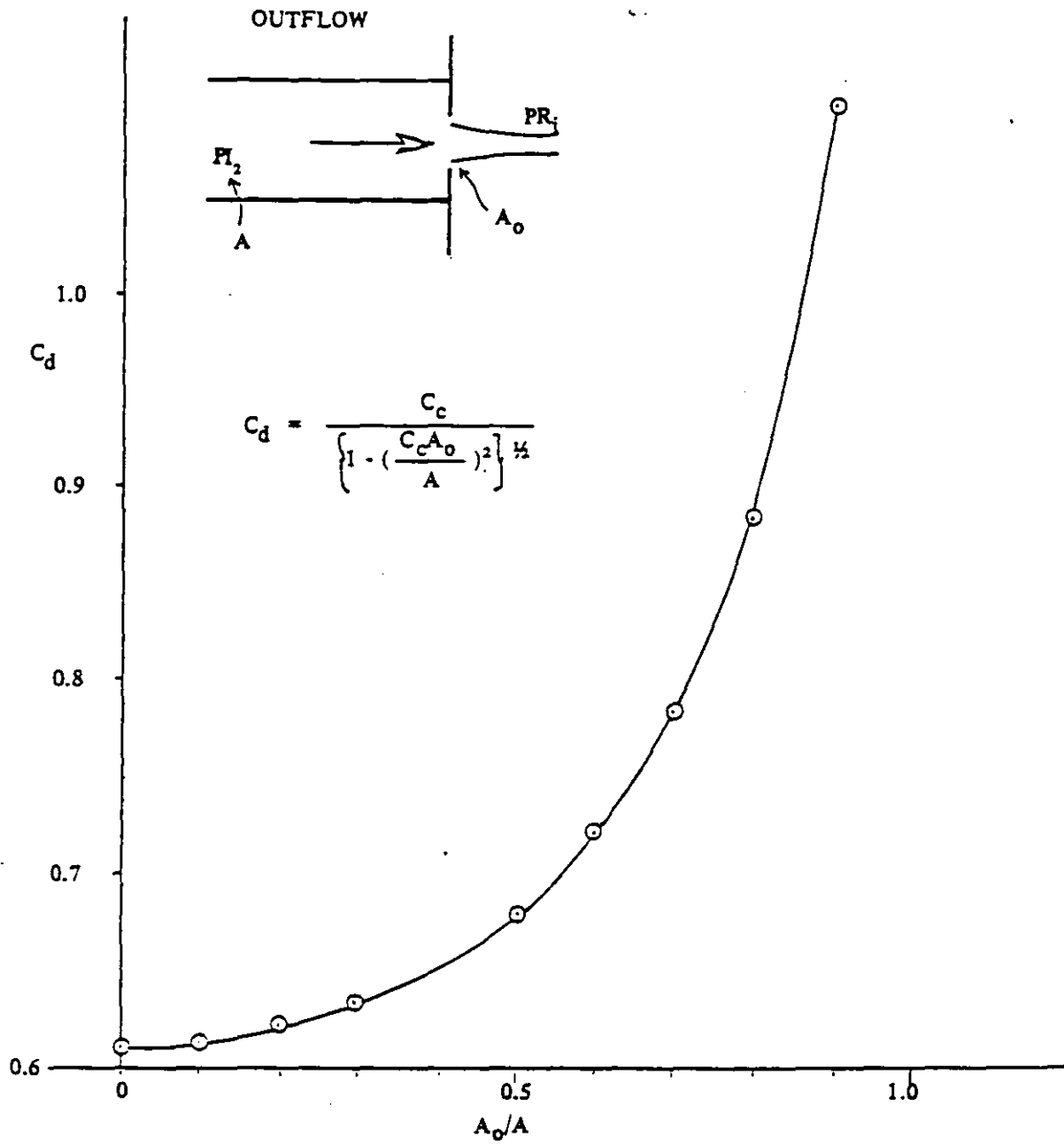
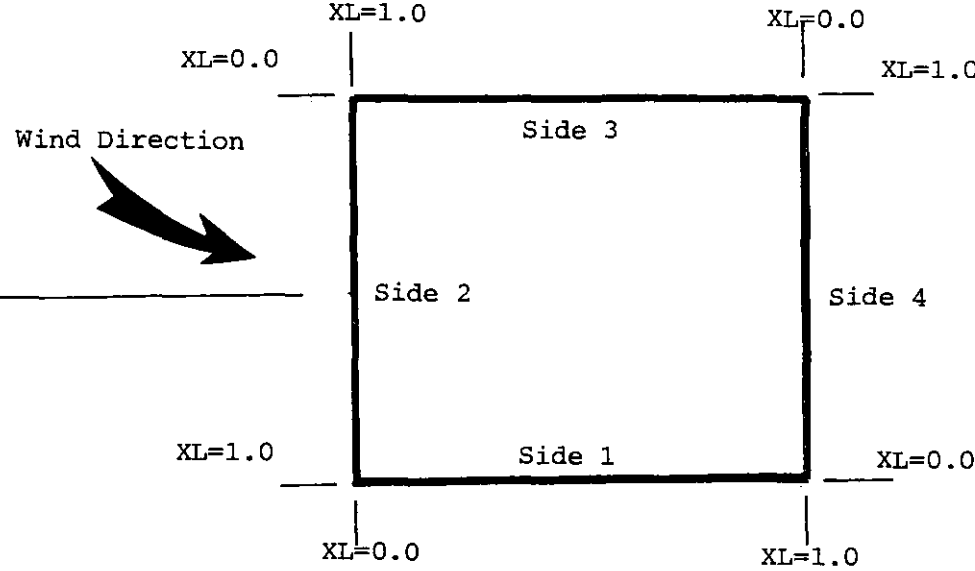
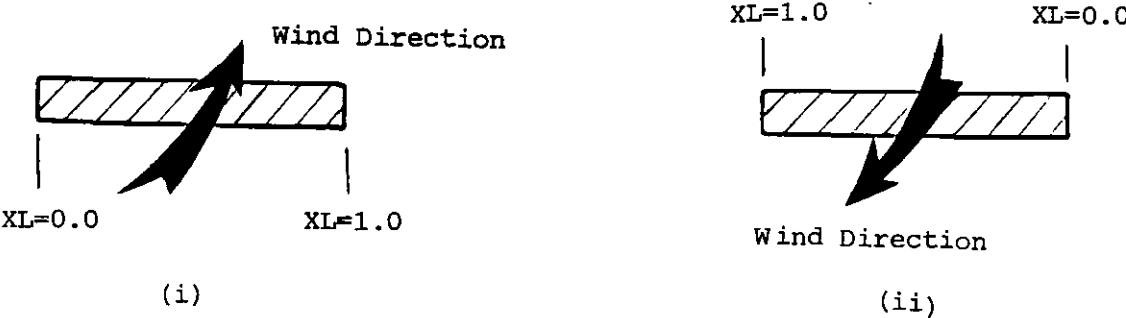

Figure 2-62 DISCHARGE COEFFICIENTS FOR HIGH REYNOLD NUMBER FLOWS (From VICKERY)



(a). Akins Definition of Origin for XL Coordinate



(b). Our Definition of Origin for XL Coordinate  
XL=0 is always the edge away from the wind direction

Figure 2-63 Origin Definition for Coordinate XL for Tall Building



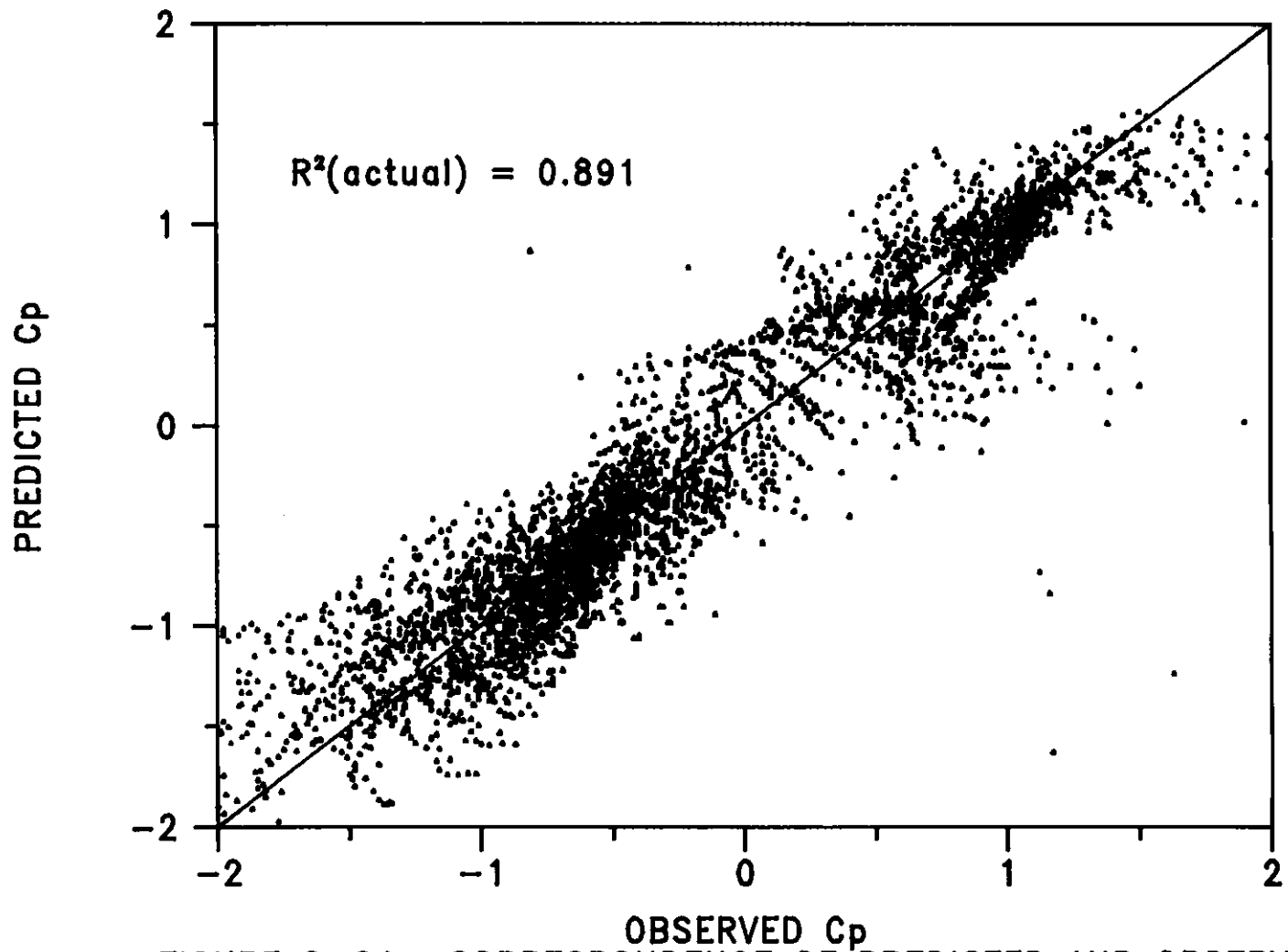
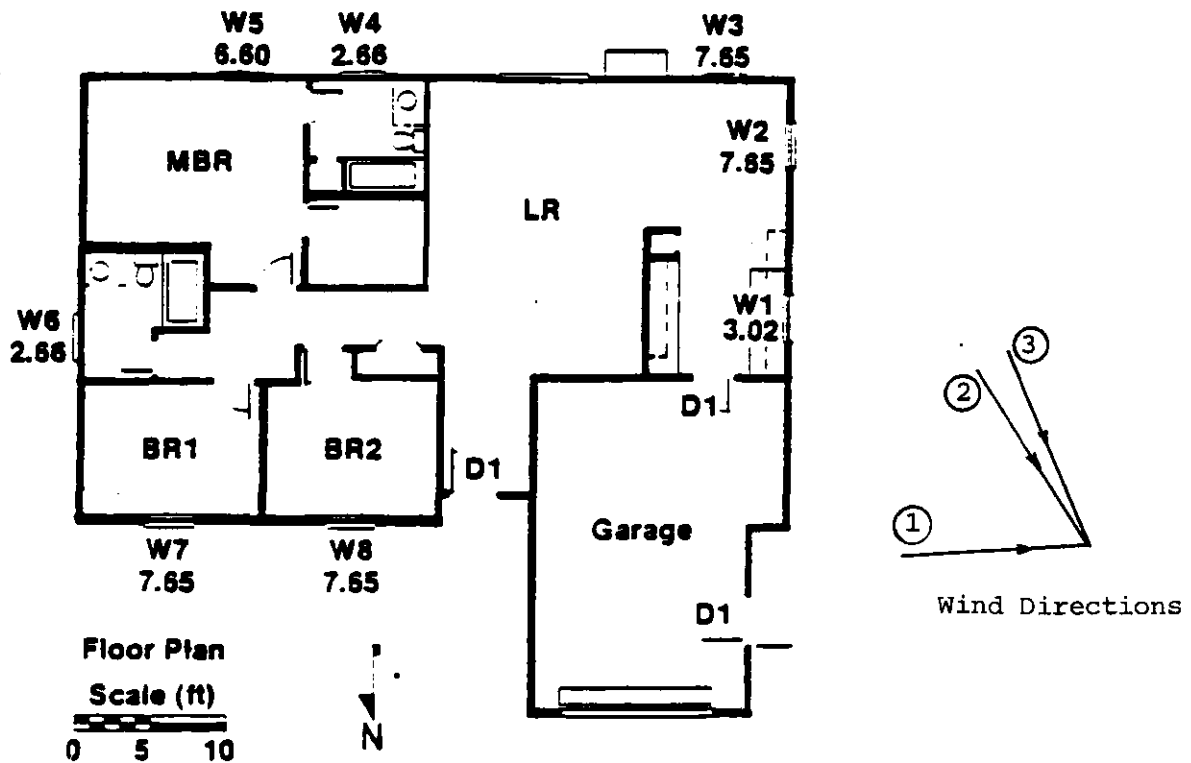

FIGURE 2-64 : CORRESPONDENCE OF PREDICTED AND OBSERVED  
Cps FOR TALL BUILDINGS



	Wind dir (degrees)	Wind Speed at 10m (mph)	Measured ACH (1982)
1	87	5.6	19.0
2	140	9.7	29.8
3	152	7.1	23.3

Figure 2-65: The plan of FSEC PV house used for ventilation experiments, showing window location, window areas (in sq. ft.) and measured air change rates for three wind directions.